



OCB (Open Circuit Bailout) Mouthpiece Maintenance Manual

Version 2.6
February 2026
Written by Tino de Rijk

Table of Contents

1. Introduction	4
1.1 Servicing	4
1.2 Two modes	4
1.3 Patented Dual Valve Technology	4
1.4 Update 11-2018: updated Yellow Lever for easier one-handed switching from OC to CC mode v.v.	5
1.5 Warranty	5
1.6 Copyright and Applicable Law	6
2. OCB Exploded Diagram and Parts List	7
2.1 RB110 Main Assembly	7
2.2 RB111 Dual Valve Assembly	8
2.3 RB112 Front Cover Assembly	9
3. Service Kit Contents and Special Tools	10
3.1 Service Kit Contents	10
3.2 Tools Needed	11
4. Disassembly Instructions	13
4.1 Remove Medium Pressure (MP) Hose	13
4.2 Remove Hose Collar Screws and Corrugated Hoses	13
4.3 Remove Yellow OC/CC Lever	14
4.4 Remove Front Cover Assembly	14
4.5 Remove White Plastic Locking Lever	15
4.6 Remove Blank End Cap and Plunger Opposite to the MP Hose Connection	16
4.7 Remove the Nuts on Both Ends of the Assembly and Remove Valve Seat Adjuster	16
4.8 Push Whole Assembly to the Right (Outside the Black Housing)	17
4.9 Remove the Lever	17
4.10 Remove the Whole Assembly from the Main Housing, Pulling it from the Left Side	19
4.11 Unscrew the Valve Seat Adjuster	20
4.12 Disassemble Counter Balance Cylinder/Spring/Piston Assembly	21
4.13 Remove Locking Screw from OCB Housing	22
4.14 Push Internal Tube Out of the Outer Tube, to the Left	23
4.15 Remove O-rings from Both Ends of the Main Housing	23
4.16 Remove O-ring from around the Breathing Hole on the Inner Tube	23
4.17 Remove the Non-Return Valves from Both Ends of the Inner Tube	24
4.18 Inspect and Optionally Replace the Mouthpiece	24
4.19 Inspect Proper Position of the Mouthpiece on the Main Housing	25
4.20 Inspect the Mouthpiece Bite itself for Damage	26
5. Clean and Replace Service Parts	27
5.1 List of Parts to be Replaced during Service	27
5.2 Ultrasonically Clean Deposits from all Metal Parts	28
5.3 Replace all O-rings with New Ones from the Service Kit	28
5.4 How to lightly grease O-rings	28
6. Assembly Instructions	30
6.1 Optionally fit a new Original Mouthpiece onto the OCB Main Housing	30
6.2 Fit new Cable Tie using Cable Tie Tension Gun	32

6.3 Screw the Valve Seat Adjuster Back into the Valve Body	33
6.4 Re-Assemble Counter Balance Cylinder/Spring/Piston Assembly	33
6.5 Insert the Valve Body into the OCB Main Housing	34
6.6 Refit Lever.....	35
6.7 Push the Assembly through the Housing to the Right to Refit O-ring	39
6.8 Refit Valve Seat Adjuster into the Valve Body End.....	40
6.9 Refit 17 mm Nuts on Both Ends of the Valve Body	40
6.10 Refit the White Plastic Locking Lever	41
6.11 Fit New O-rings Inside Both Ends of the Outer Housing.....	42
6.12 Replace the Non Return Valves into Both Ends of the Inner Tube.....	42
6.13 Fit a New O-ring Around the Breathing Hole in the Inner Tube	43
6.14 Insert the Internal Tube Back into the Outer Housing, from the Left.....	44
6.15 Replace Locking Screw into the Outer Housing	44
6.16 Refit Yellow Lever on Left Side of Tube.....	44
6.17 Refit Front Cover Assembly	45
6.18 Refit Corrugated Hoses and Hose Collar Screws.....	46
6.19 Refit Blank End Cap and Plunger	47
6.20 Refit MP Hose.....	48
6.21 Update 11-2018: Refit the updated Yellow Lever on Left Side of Tube.....	49
7. Testing Instructions	51
7.1 Check Airtight Sealing in OC Mode	51
7.2 Check Airtight Sealing in CC Mode.....	51
7.3 Check for Smooth Movement between OC and CC Mode	51
7.4 Remove Front Cover Assembly	52
7.5 Adjust Right-hand Valve Adjuster, Checking Correct Lever Height with RBTOOL15	52
7.6 Adjust Left-hand Valve Adjuster, Checking Correct Lever Height with RBTOOL15	53
7.7 Refit Front Cover Assembly	54
7.8 Test for Leaks and Breathing Quality by Attaching the OCB with its MP Hose onto a 50 bar Oxygen-Compatible Clean Air Source.....	54
7.9 Check Proper Breathing also in Right Hand Mode	54

1. Introduction

1.1 Servicing

Before servicing this OCB mouthpiece, you must receive instruction and certification in the maintenance of this OCB by the AP Diving factory.

Without the correct training it is possible to configure the OCB incorrectly in an unsafe manner.

Factory / Dealer prescribed service for this OCB mouthpiece is recommended at least once annually.

The Inspiration, Evolution and Evolution+ closed circuit rebreathers' CE certification to EN14143 is unaffected by the addition of this OCB mouthpiece.

This OCB mouthpiece meets the requirements of the Personal Protective Equipment Directive 89/686/EEC – CE certification when fitted to a first stage regulator conforming to EN250 or EN13949 and to an AP Diving rebreather.



WARNING: when servicing the OCB, it is VERY important that all parts that may suffer wear and tear get replaced. It is also very important that the correct special tools are used to avoid damaging any part of the OCB in the disassembly and assembly process. Please don't try to save money by re-using parts that really should be replaced during a proper servicing action.



The numbers between brackets after the part names in the disassembly and assembly chapters correspond to the sequence numbers in the diagrams in chapter 2.

1.2 Two modes

The OCB Mouthpiece has 2 Modes:

- CC: Closed Circuit rebreather diving position.
- OC: Open Circuit diving position. This is the BAIL-OUT mode.

The two modes are selected by rotating the lever (M16) forwards or backwards, which in turn rotates the internal components within the main body. The Rebreather mode is activated by rotating the lever to the backward position where the lever is in line with the mouthpiece. The Open Circuit mode is activated when the lever is rotated forward to the 'up' position.

The lever is best operated by the diver resting his right hand on top of the corrugated hose and placing an extended thumb between the two lugs of the lever.

1.3 Patented Dual Valve Technology

The OCB Mouthpiece utilises AP's new patented Dual Valve Technology.

This new demand valve enables the diver to quickly and easily change the medium pressure (7 to 14 bar) supply hose routing from left to the right hand side, without the need for major disassembly, adjustment or any special tools.

The Dual Valve can be switched between the left and right hand side in 5 simple steps:

1. Turn the gas off and purge.
2. Unscrew (anti-clockwise) the supply hose (M1) and then the 9/16" UNF blanking cap (V7) from the opposite end until the threads disengage, then pull withdrawing the plunger (V6).
If a tool needs to be used to undo these fittings, protect the plastic moulding by preventing the Dual Valve Body from rotating by using two 17mm spanners, one on the adjacent hexagon nut.
3. Fully screw the plunger back into the blanking cap until the threads disengage and you can feel movement in the plunger. Then gently slide the plunger into the opposite side of the dual valve.
4. Screw the blanking cap on until it is tight against the shoulder, covering the thread. You should be able to do this up without tools. If resistance is met, you need to ensure the plunger is properly located in the blanking cap (as Step 3. above) and the threads are clean and sufficiently lubricated with oxygen compatible grease. While finger-tight is sufficient, it is prudent to just nip it up lightly using two 17mm spanners.
5. Reconnect the medium pressure supply hose. Turn the gas on slowly and test for leaks and breathing performance prior to diving.



WARNING: When switching the valve from left to right hand side hose routing, use two 17mm spanners, one on the hexagon of the blanking cap or hose and the other on the adjacent hexagon immediately next to the valve body. Using just one spanner on the blanking cap or hose may damage the valve body.



WARNING: If additional components are used in the medium pressure gas supply, for instance a Gas Connection System or Gas Switching block, it is important to realise that these may interfere with the gas flow to the OCB and degrade the breathing performance, preventing the OCB from supplying sufficient gas to a hard working diver at depth. Additionally, if they interrupt the gas supply the OCB may be critically damaged on descents.

1.4 Update 11-2018: updated Yellow Lever for easier one-handed switching from OC to CC mode v.v.

In November 2018, AP Diving introduced an updated version of the yellow switching lever. This updated version facilitates a much easier one-handed operation of the OCB.

This has been realised by repositioning the two protruding lever tabs on the lever to a new position whereby the OCB can be switched from the open to the closed position v.v. with a pinching movement between the associated lever tab and the blank endcap.

The updated lever is fully backwards compatible with all existing OCB's, i.e. it can be retroactively fitted to any OCB already out in the field by simply swapping out the old version for the updated one.

Fitting instructions for the updated lever can be found in paragraph 6.21.

1.5 Warranty

This OCB mouthpiece is covered by AP Diving's 1 year warranty against defects in materials or workmanship. This warranty is only extended to the original purchaser, and is not transferable. For more information, be sure to read the warranty section of the user manual, and the purchaser should save the sales receipt.

A copy of the receipt must be presented whenever obtaining warranty service.

1.6 Copyright and Applicable Law

This Maintenance Manual is copyrighted, all rights reserved. It may not, in whole or in part, be copied, photocopied, reproduced, translated, or reduced to any electronic medium (including the Internet) or machine readable form without prior consent in writing from AP Diving.

All products are sold on the strict understanding that only English Law applies in cases of warranty claims and product liability, regardless of where the equipment is purchased or used. Should a claim be made then the venue for this would be in Truro, England.

© 2018 AP Diving
OCB Maintenance Manual

2. OCB Exploded Diagram and Parts List

2.1 RB110 Main Assembly

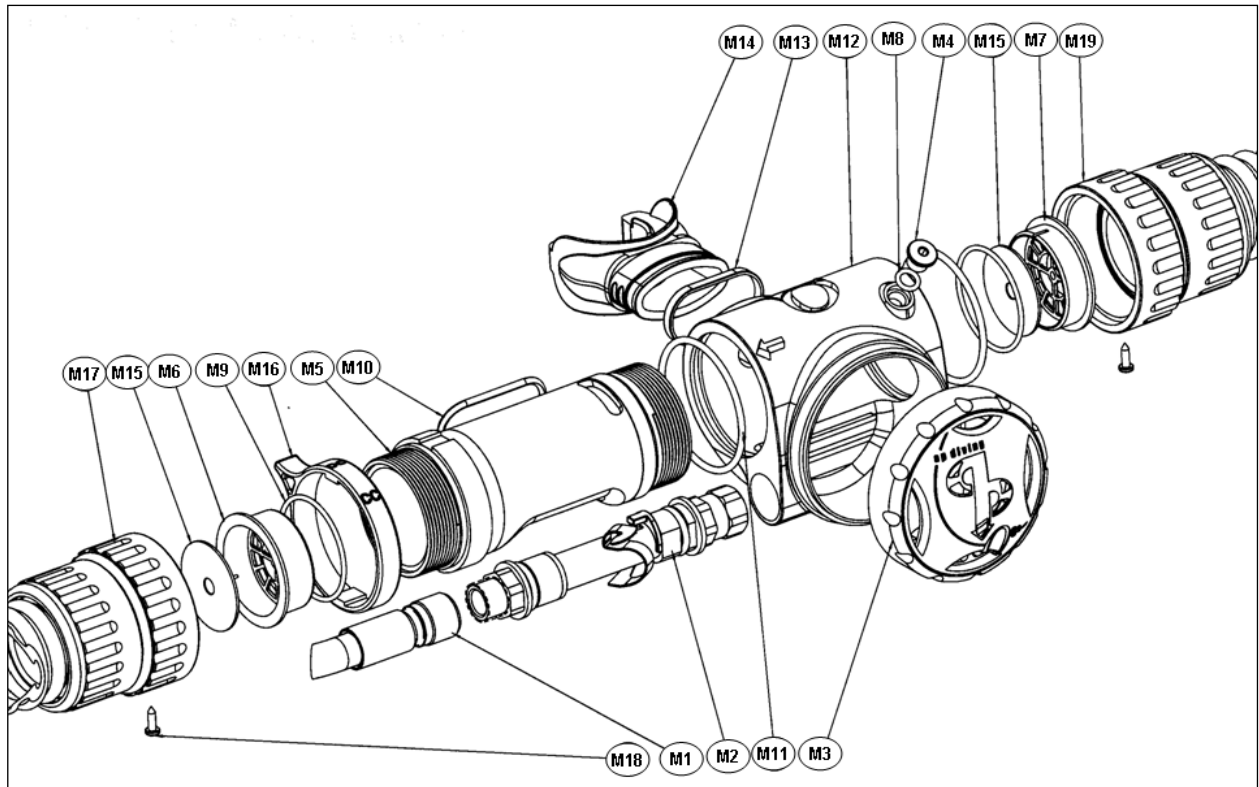

<u>NUMBER</u>	<u>DESCRIPTION</u>	<u>PART NUMBER</u>	<u>QUANTITY</u>
M1	Inflator Hose Assembly	AP300	1
M2	Dual Valve Assembly	RB111	1
M3	Front cover Assembly	RB112	1
M4	Location Screw	RB114_1	1
M5	Inner Tube	RB116	1
M6	Valve Holder RH	RB02_04	1
M7	Valve Holder LH	RB02_03	1
M8	O Ring	BS010 N70	1
M9	Non-return O Ring	BS029 N70	2
M10	Mouthpiece Seal	BS125 N70	1
M11	Inner O Ring	BS48x2.5 N70	2
M12	Main Outer Housing	RB115	1
M13	Cable tie (Ty-rap)	AP21	1
M14	Mouthpiece	AP16	1
M15	One Way Valve	RB02_05	2
M16	Lever	RB116_1	1
M17	Exhale Hose Assembly	RB07_03	1

<u>NUMBER</u>	<u>DESCRIPTION</u>	<u>PART NUMBER</u>	<u>QUANTITY</u>
M18	Hose Collar Screw	SC102	2
M19	Inhale Hose Assembly	RB07_04	1

2.2 RB111 Dual Valve Assembly

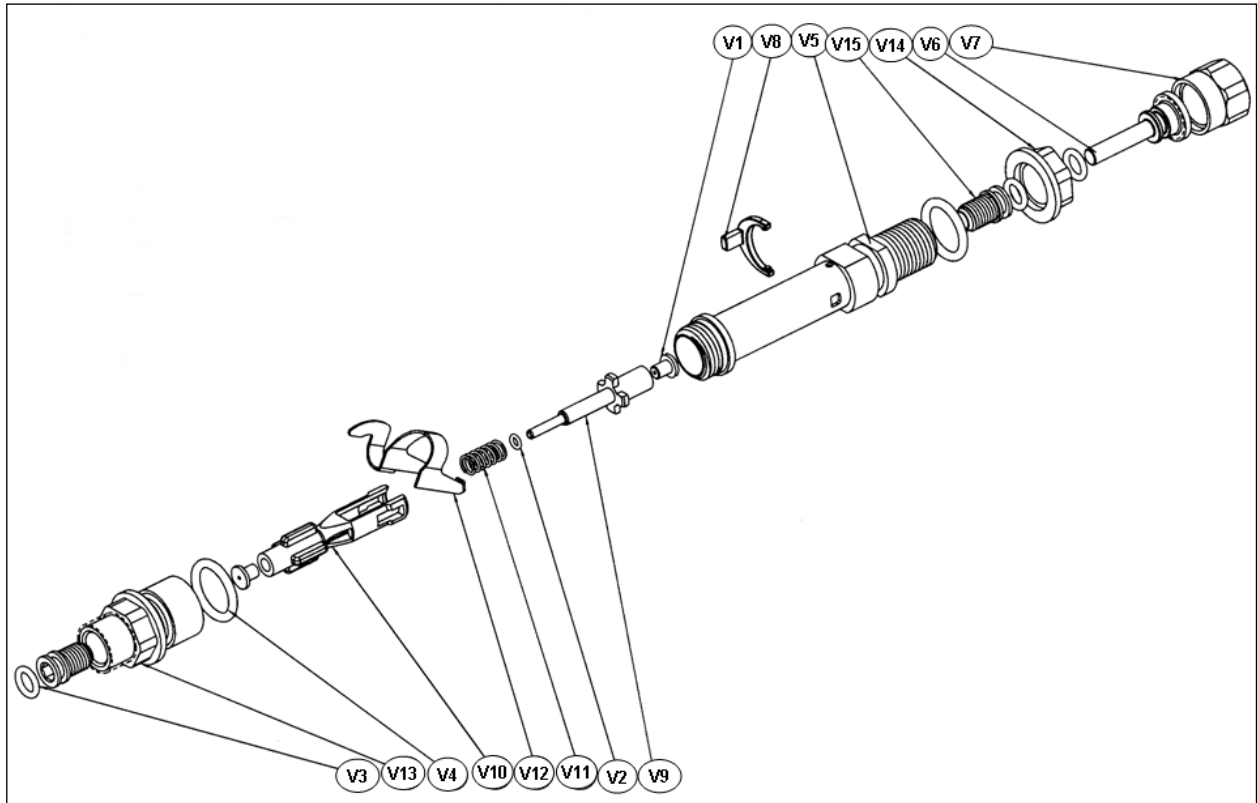

<u>NUMBER</u>	<u>DESCRIPTION</u>	<u>PART NUMBER</u>	<u>QUANTITY</u>
V1	Silicone Valve Seat	AP100_23	2
V2	O Ring	BS2.5x1 N70	1
V3	O Ring	BS010 N70	3
V4	O Ring	BS14.5x2.5 N70	2
V5	Valve Body	RB111_1	1
V6	Plunger	RB111_10	1
V7	9/16" Blanking Plug	RB111_11	1
V8	Locking Lever	RB111_12	1
V9	Counter Balance Piston	RB111_2	1
V10	Counter Balance Cylinder	RB111_3	1
V11	Dual Valve Spring	RB111_5	1
V12	Lever	RB111_6	1
V13	Valve body End	RB111_7	1
V14	Valve Locking Nut	RB111_8	1
V15	Valve Seat Adjuster	RB111_9	2

2.3 RB112 Front Cover Assembly

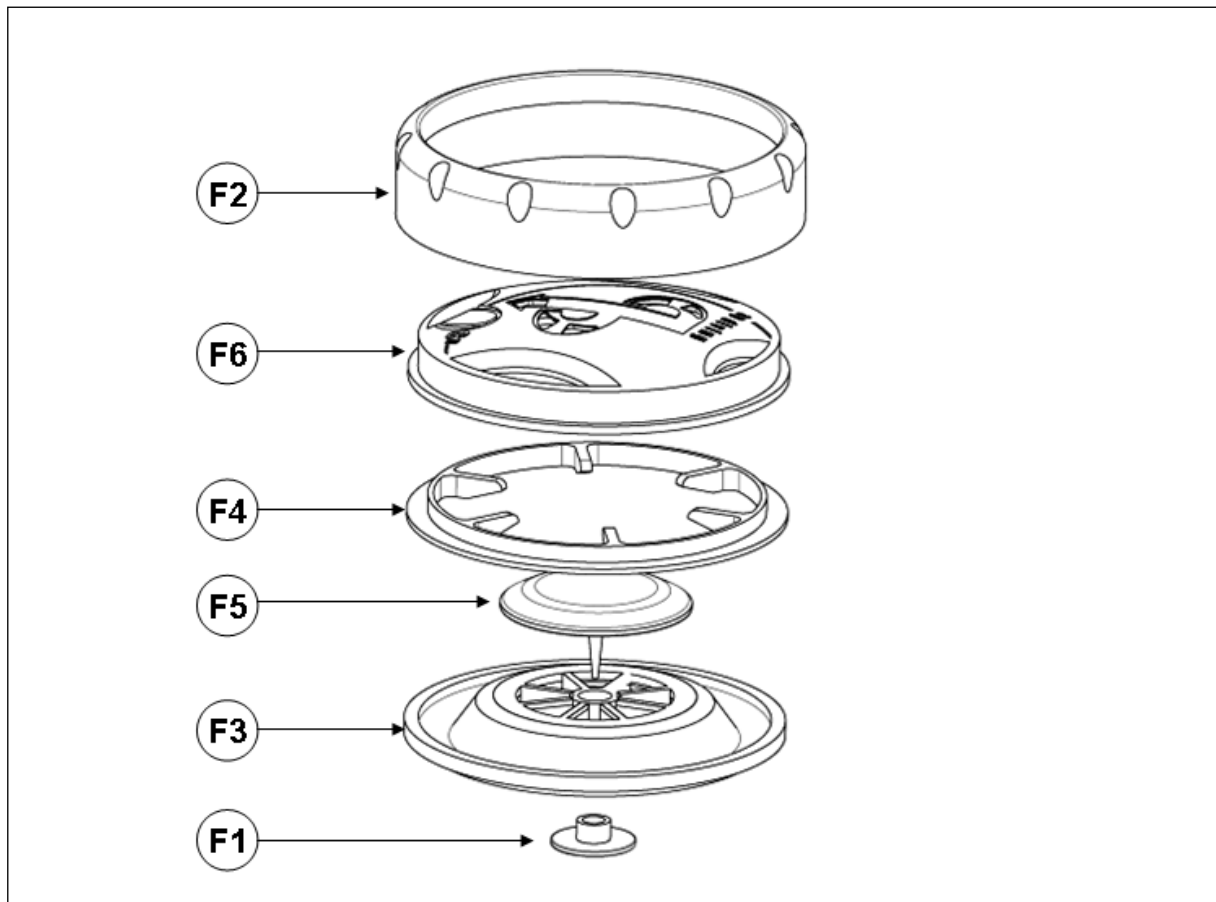

<u>NUMBER</u>	<u>DESCRIPTION</u>	<u>PART NUMBER</u>	<u>QUANTITY</u>
F1	Diaphragm Lever Pad	RB112_6	1
F2	Locking Ring	RB112_1	1
F3	Diaphragm	RB112_5	1
F4	Skid Disk	RB112_3	1
F5	Exhaust Diaphragm	RB112_4	1
F6	Rubber Cover	RB112_2	1

3. Service Kit Contents and Special Tools

3.1 Service Kit Contents

⚠ WARNING: When replacing O-rings, next to the size, the hardness of the O-rings (declared in degrees Shore, and indicated by the suffixes N70 and N90) is ESSENTIAL for proper operation.

The N70 or N90 hardness of the O-rings is deliberately selected by AP Diving.

If you choose to select your O-rings to come from another source than AP Diving, make sure you select the right type in size AND hardness.

When servicing the OCB, the following parts need to be replaced:

<u>NUMBER</u>	<u>DESCRIPTION</u>	<u>PART NUMBER</u>	<u>QUANTITY</u>
M8	O Ring on Location Screw	BS010 N70	1
M9	Non-return Holder Seals	BS029 N70	2
M10	Mouthpiece Seal on Inner Tube	BS125 N70	1
M11	Inner O Rings on inside of Main Body	BS48x2.5 N70	2
V1	Silicone Valve Seats	AP100_23	2
V2	O Ring on Counter Balance Piston	BS2.5 x 1 N70	1
V3	O Rings on Valve Seat Adjusters and Plunger	BS010 N70	3
V4	O Rings on Regulator Valve Body	BS14.5x2.5 N70	2

The following items are to be replaced as required, depending on inspection outcome:

M6 + M15	Non-return Valve Holder RH + One Way Valve	RB02_04 + RB02_05	1
M7 + M15	Non-return Valve Holder LH + One Way Valve	RB02_03 + RB02_05	1
F3	Diaphragm	RB112_5	1
M13	Cable tie for mouthpiece	AP21	1
M14	Mouthpiece	AP16	1



3.2 Tools Needed

There are two special tools needed for proper servicing of the OCB. In addition to these, normal tools needed are:

- 5 mm Allen key;
- 2 x 17 mm spanner and torque wrench, set to 7 Nm;
- Oxygen-compatible grease;
- Scalpel;
- Various small screwdrivers (both flat and Phillips);
- (access to) an ultrasonic bath for cleaning the metal parts.

The special tools needed are:

- **RBTOOL13: Position-fixing tool for Counter Balance Cylinder.**
See paragraph 4.9 for correct use.



- **RBTOOL15: OCB Lever Adjust Tool.**
See paragraph 7.5 and further for correct use.



- **Cable Tie tension gun.**

This tool can be found amongst others at <https://www.rapidonline.com/anvil-av-cttg-cable-tie-tension-gun-86-0522>.

This tool is needed for the proper tensioning and cutting of the cable tie that seals the mouthpiece onto the OCB main housing.



A more expensive tension gun with more adjustment capabilities can be found here: <http://uk.farnell.com/hellermann-tyton/mk9-9a/installation-tool-t80-ties/dp/1296251>



⚠ WARNING: Do NOT use aggressive chemicals. They might damage the metal coating. Use an ultrasonic cleaning bath with a suitable cleaning fluid. A very good cleaning fluid is Biox "O2" immersion fluid. See WWW.BIOXINT.COM for further information and distributors. The use of rubber gloves while re-assembling the OCB is highly recommended to avoid rendering the OCB oxygen unclean due to human touch.

4. Disassembly Instructions

4.1 Remove Medium Pressure (MP) Hose



- Remove the MP hose
- Remove the O-ring in the hose and replace with a new one

4.2 Remove Hose Collar Screws and Corrugated Hoses



- Mark the position of the stainless steel screws before removing
- Remove the two S/S screws (one in each hose collar)
- Unscrew both corrugated hoses
- Visually inspect corrugated hoses for wear and tear while stretching them a bit
- Inspect the sealing O-rings inside the hose collars. If damaged or flat, replace them.

4.3 Remove Yellow OC/CC Lever

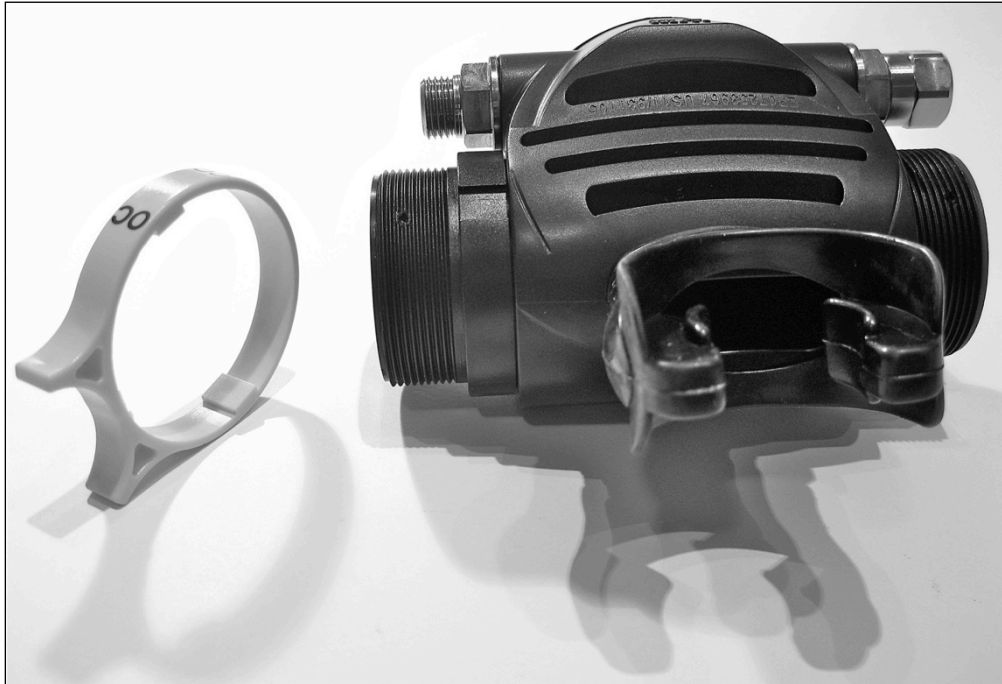

4.4 Remove Front Cover Assembly



- The front cover assembly consists of four parts, as shown in the picture.
- Inspect the diaphragm with its integrated exhaust valve (on the left of the picture above) for wear and tear, and check that the exhaust valve is clean and still properly seals.

4.5 Remove White Plastic Locking Lever



- Gently pry the locking lever out of its position, using a very small screwdriver (e.g. a watch repair screwdriver as shown in the picture).

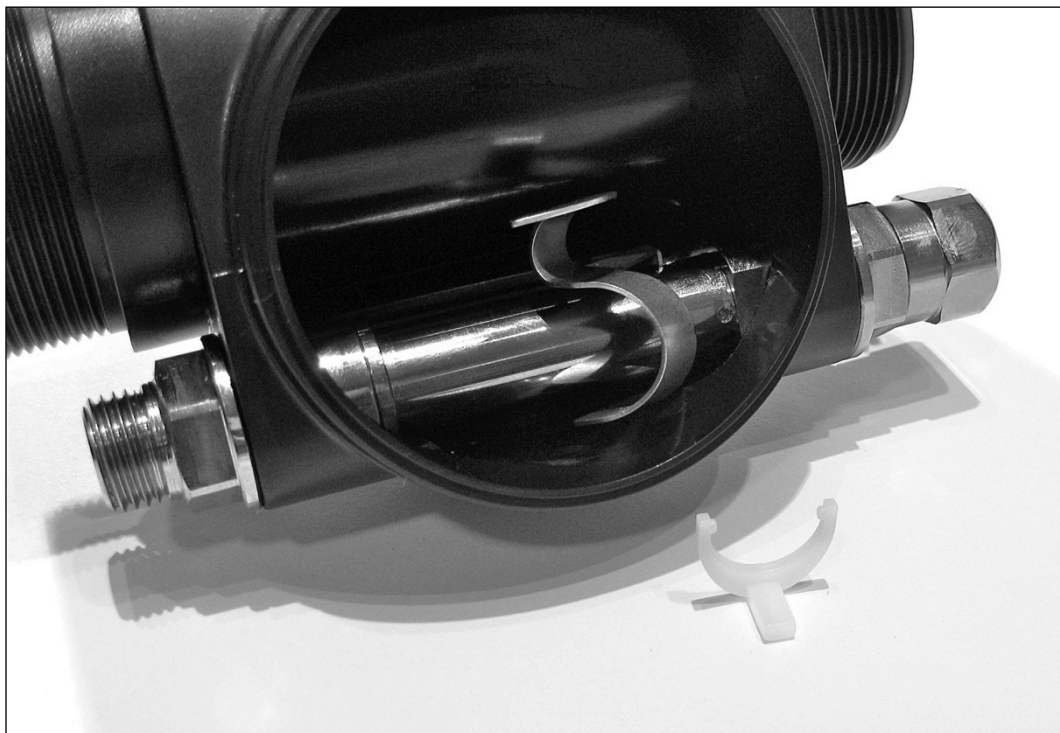

- Make sure you do NOT damage the small location cams on the curved part of the locking lever. They have an important role in fixing the locking lever into its position.

4.6 Remove Blank End Cap and Plunger Opposite to the MP Hose Connection

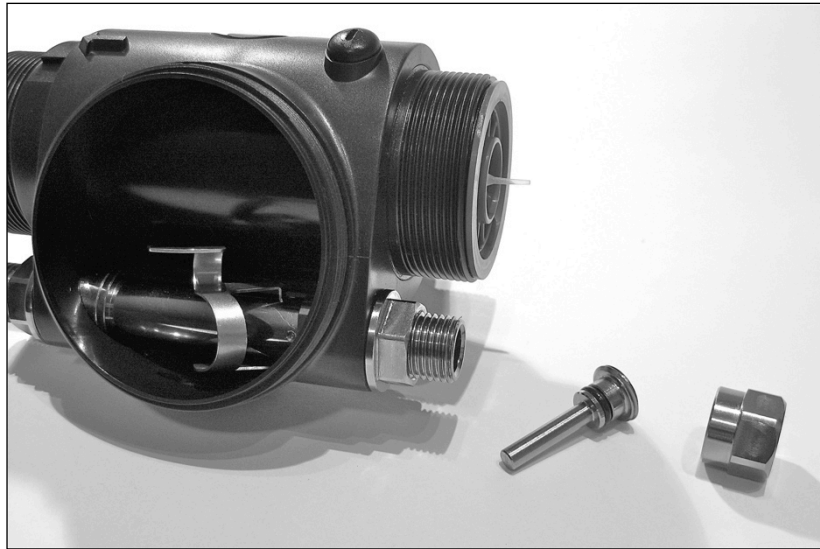

- Removing the end cap will also remove the plunger
- Unscrew the plunger from the end cap. Optionally use a 17 mm wrench.

4.7 Remove the Nuts on Both Ends of the Assembly and Remove Valve Seat Adjuster



- Use a 17 mm spanner to remove the left and right nuts
- The left nut will be slightly stiffer, as it has an O-ring inside that will cause friction

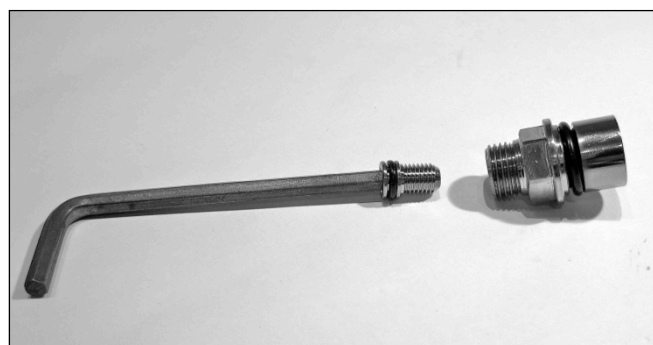

- Next insert a 5 mm Allen key into the valve body end, preferably one with a round top to avoid damage, and unscrew the valve seat adjuster
 - Unscrew counter-clockwise
- Remove the O-rings from the valve body end and the valve seat adjuster and replace them with new ones after cleaning.

4.8 Push Whole Assembly to the Right (Outside the Black Housing)

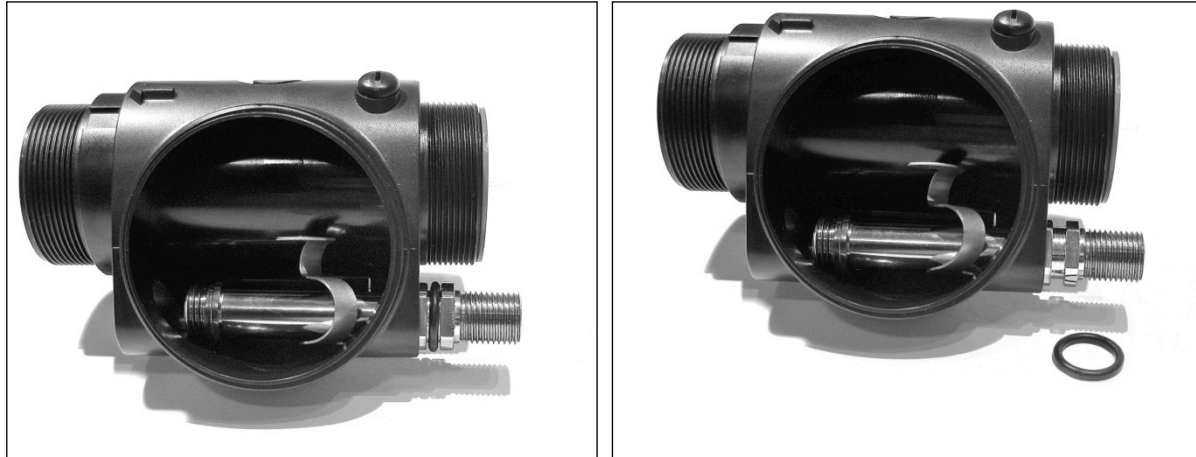

- Push the whole internal assembly out of the black housing, exposing the sealing O-ring
- Remove the O-ring, as shown in the right picture above.

4.9 Remove the Lever



- Push the internal assembly back into the main housing, to make more room for your fingers for the following steps
- Use special tool RBTOOL13 (see paragraph 3.2) and insert it into the left side of the regulator body.
 - Make sure the slots in the special tool hook onto the “wings” of the counter balance cylinder inside.
 - If inserted correctly, the special tool only sticks out a few millimetres.
- Insert the steel plunger into the opposite end of the regulator body.



- Now pinch the whole assembly between thumb and index finger to compress the spring, pushing both the special tool and the plunger all the way in, as shown in the picture above.
- If done correctly, the lever will lose its tension and fall flat on the steel inner tube. The pinching motion releases the pressure on the internal spring.



- While keeping the steel tube of the inner assembly firmly pinched, gently pry out the lever.
 - Make sure you do not bend the legs of the lever while removing it. Be gentle; wiggle it a bit, do not use force.



- The picture above shows the removed lever, as well as one of holes in the steel tube of the inner assembly from which it was removed.

4.10 Remove the Whole Assembly from the Main Housing, Pulling it from the Left Side



- First remove the special tool and plunger that were used for compressing the spring.
- Next remove the counter balance cylinder/spring/piston assembly.



- Next remove the steel tube from the main housing.

4.11 Unscrew the Valve Seat Adjuster

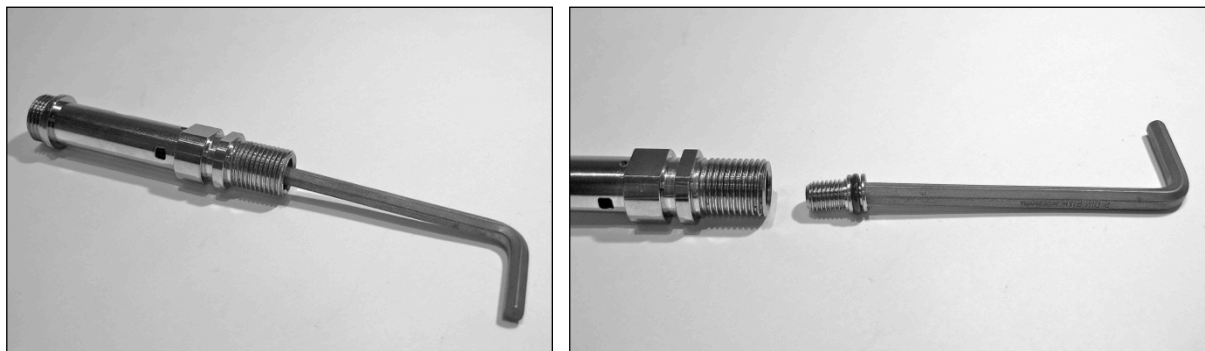

- Insert a 5 mm Allen key into the valve seat adjuster inside the valve body, preferably one with a round top to avoid damage, and remove the insert
 - Unscrew counter-clockwise
- Remove the O-ring from the insert and replace with a new one after cleaning.

4.12 Disassemble Counter Balance Cylinder/Spring/Piston Assembly

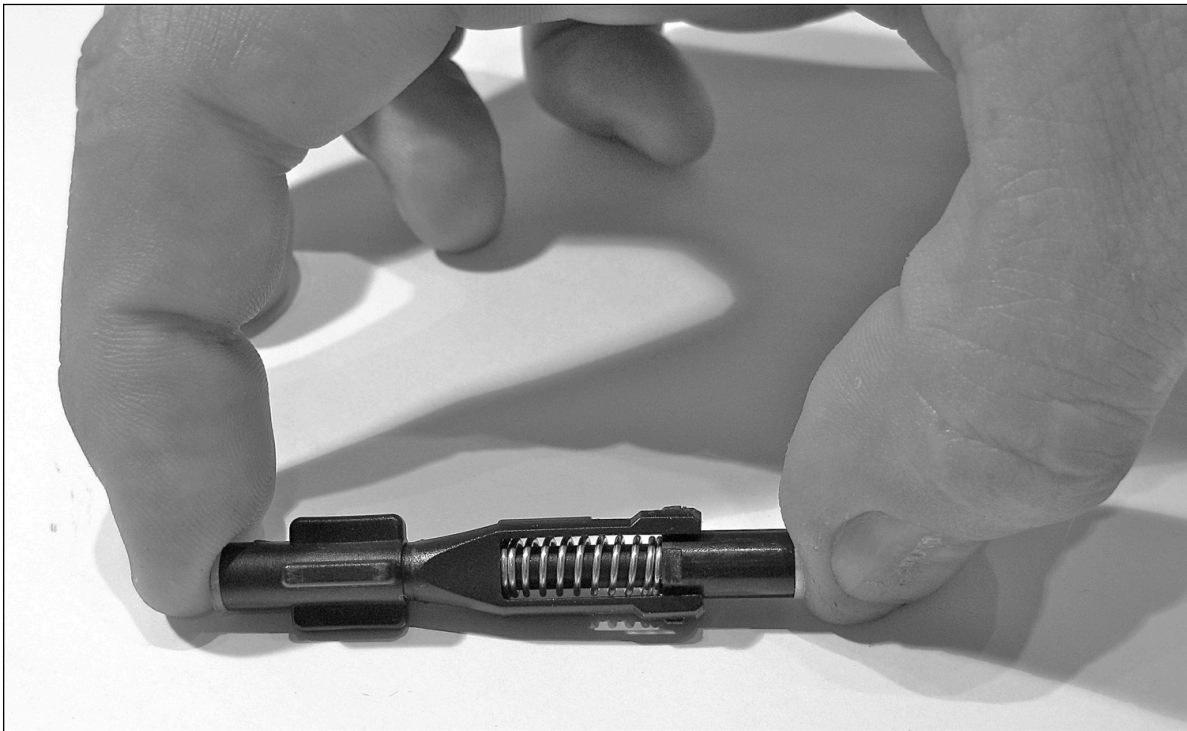

- Pinch the assembly, and gently pry out the legs of the cylinder-part to release the piston.
 - Take care not to bend or break the legs of the cylinder part.

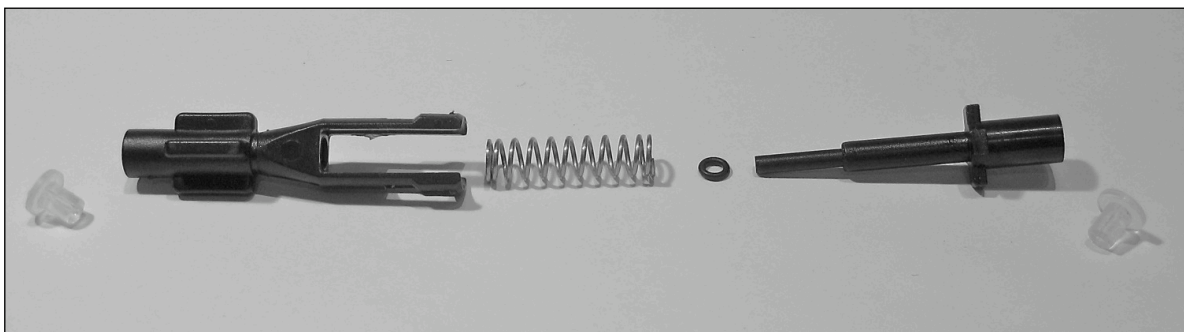

- Next, remove:
 - The internal spring
 - The small O-ring on the piston shaft
 - The two silicone valve seats on the ends of the cylinder and piston
- The assembled parts should look like the picture above.
- The small O-ring and the silicone valve seats must be replaced by new ones.



NOTE: The counter balance cylinder/spring/piston assembly as shown in the picture above and on other pictures is black in colour. However, APD changed the colour of the assembly from black to white in the beginning of 2009. This was only done to better facilitate the visibility during assembly. The black and white parts are manufactured from the same material. As a reference the pictures on the next page show the same assembly in white.

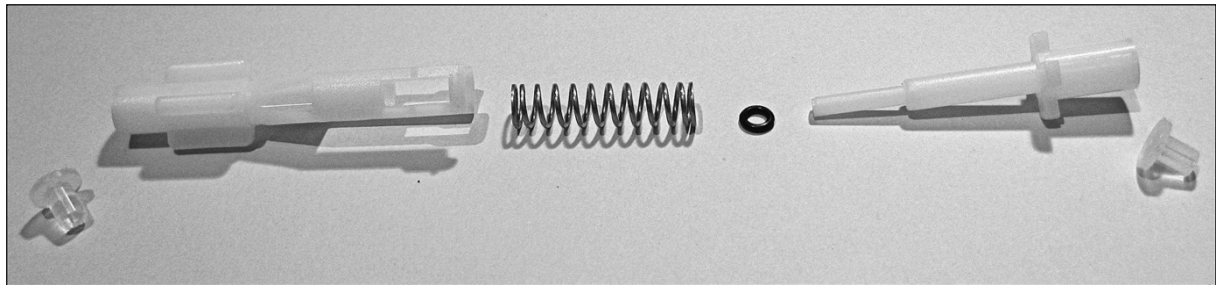
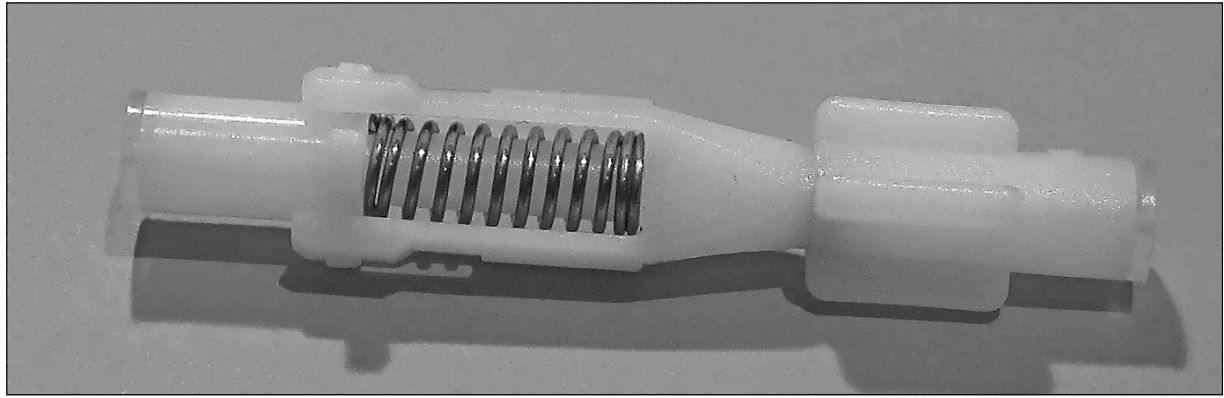

4.13 Remove Locking Screw from OCB Housing

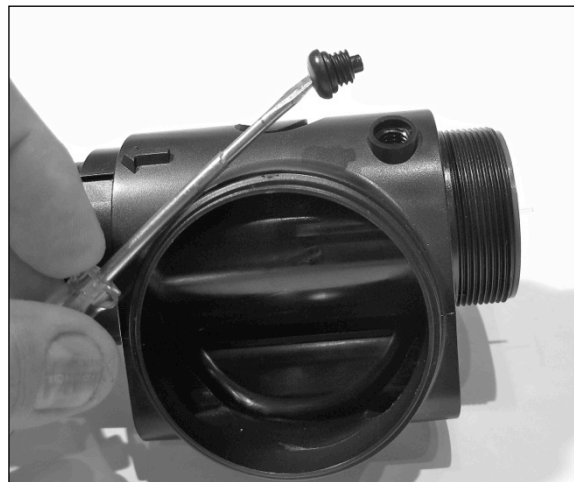

- Use a 3.5 mm screwdriver to remove the plastic locking screw



- Remove the O-ring from the black plastic locking screw

4.14 Push Internal Tube Out of the Outer Tube, to the Left



4.15 Remove O-rings from Both Ends of the Main Housing

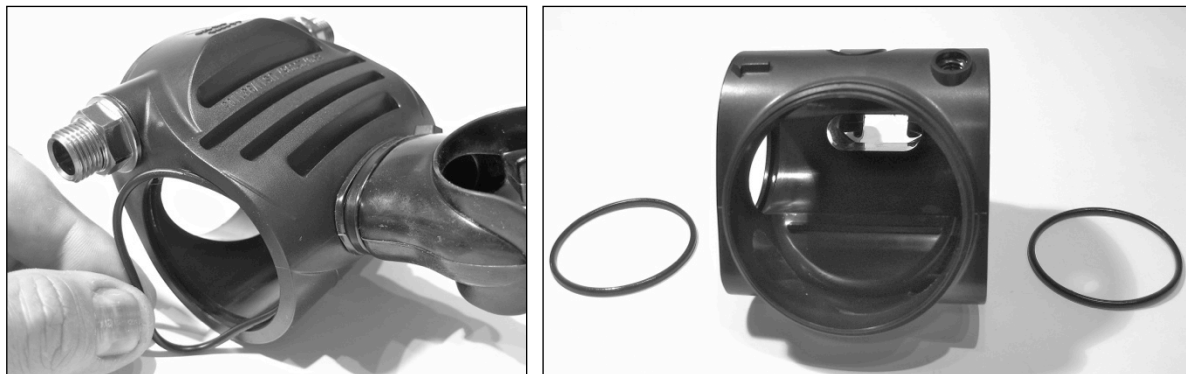

4.16 Remove O-ring from around the Breathing Hole on the Inner Tube



4.17 Remove the Non-Return Valves from Both Ends of the Inner Tube

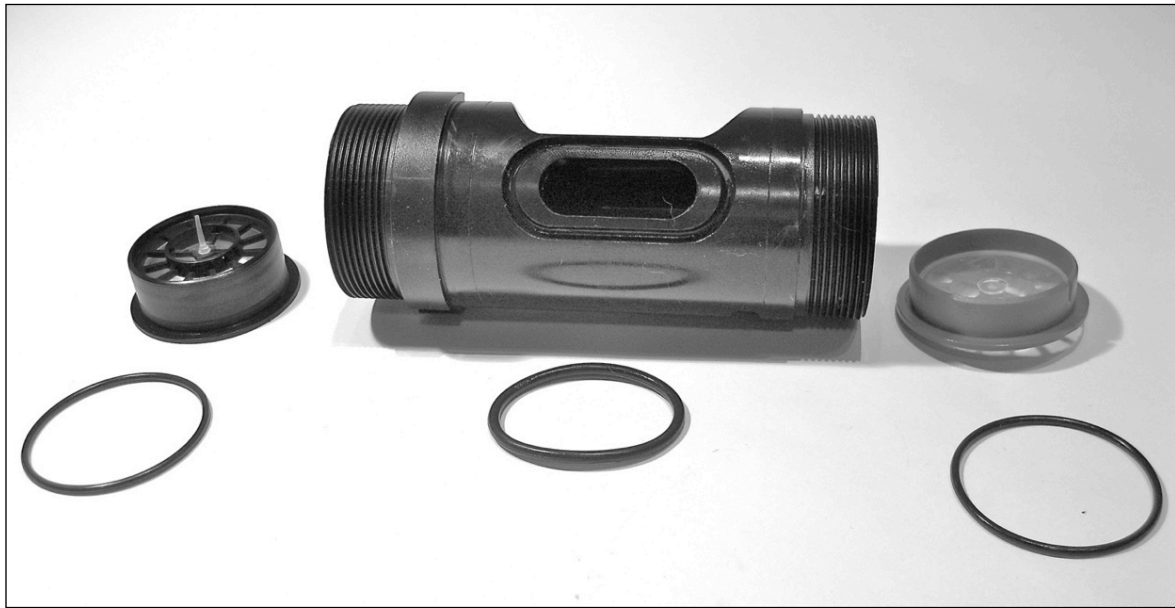

- Remove and inspect the non return valves
 - Make sure the silicone diaphragms do not show wear and tear, and inspect whether they still seal ok by gently trying to suck air through them
- Remove the O-rings from the valve bodies. Replace them with new ones after cleaning.

4.18 Inspect and Optionally Replace the Mouthpiece

- It is not necessary to replace the mouthpiece at each service interval, but it IS necessary to carefully inspect it for wear & tear and correct fitting.
- If the mouthpiece is not correctly located, as indicated in the pictures below, or if there is any sign of damage or deterioration, the mouthpiece should be removed and replaced.
- Removing the cable tie allows for easier and proper inspection but must only be removed if you have sufficient ability, tools and parts to properly re-secure the new mouthpiece.
- Inspect for proper positioning of the mouthpiece on the main housing, as indicated below.
 - When replacing the cable tie, make sure to use an original one from AP Diving. The original ones are guaranteed to be able to handle the significant amount of tension that needs to be applied to ensure a firm fixation of the mouthpiece onto the main housing.
 - If the cable tie is not tightened sufficiently, there is a risk of the mouthpiece coming adrift from the main housing during the dive; likewise, if an inferior quality cable tie is used.
- When removing the old cable tie from the mouthpiece take extra care not to damage the mouthpiece in the process.
 - The best way to remove the cable tie is to cut the closure in a vertical way, as shown in the pictures below.

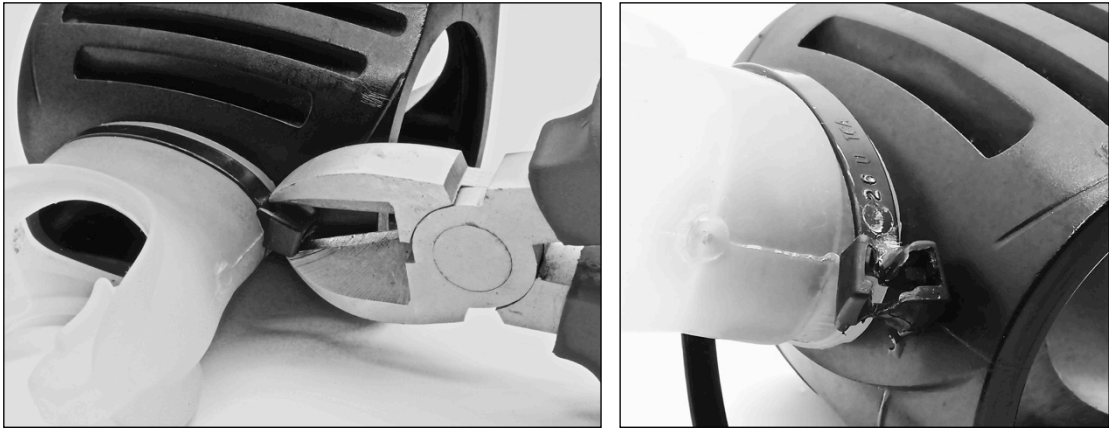

4.19 Inspect Proper Position of the Mouthpiece on the Main Housing

- The original AP Diving mouthpieces have a recess on the inside that slips onto the raised rim on the main housing, as shown on the pictures below:

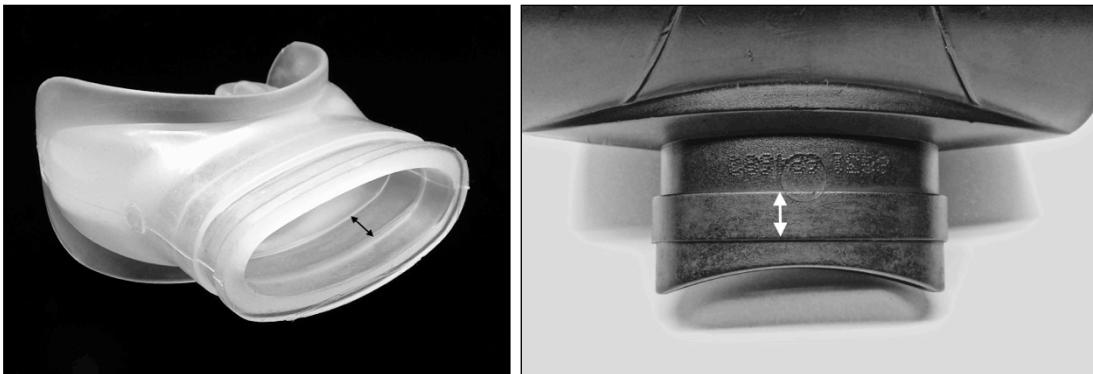

- The picture below shows correct positioning of the mouthpiece on the main housing. Note: there is no visible gap between the end of the mouthpiece and the main housing.



- The pictures below show INCORRECT positions of the mouthpiece on the main housing. Note the visible gap between the end of the mouthpiece and the main housing. In the second example, the mouthpiece is also not properly aligned horizontally.
 - Both incorrect positions result in the recess inside the mouthpiece not hooking onto the raised rim of the main housing.

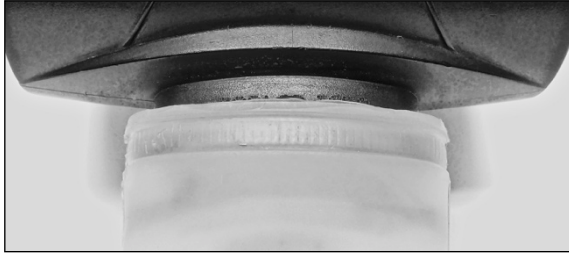

INCORRECT: visible gap

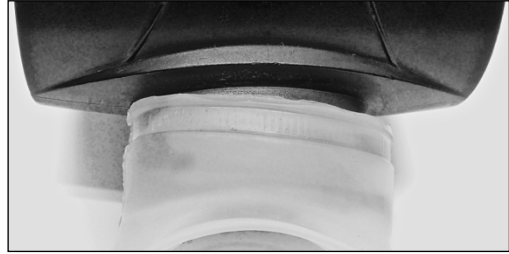

INCORRECT: no horizontal alignment

4.20 Inspect the Mouthpiece Bite itself for Damage

- Inspect the mouthpiece bite itself carefully for any damage along the outside seam or on the bite lugs of the mouthpiece. See arrows below for areas to be inspected.
 - If any damage is found, replace the mouthpiece.

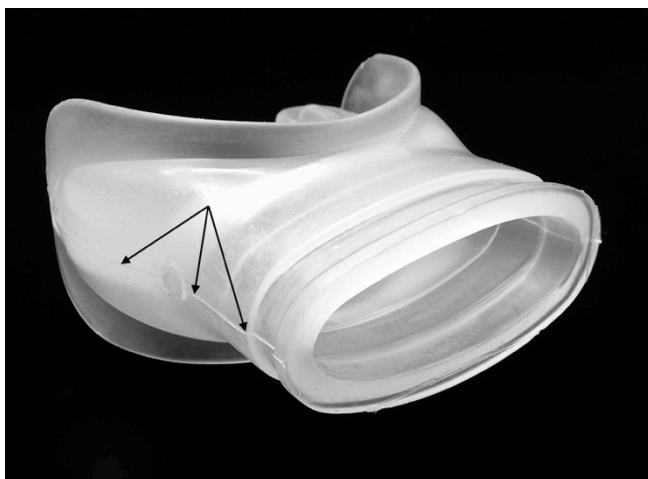
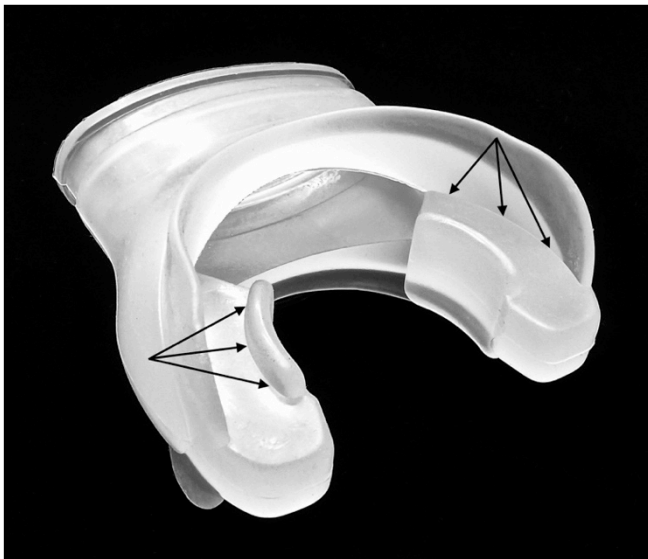

5. Clean and Replace Service Parts

The servicing of the OCB inflator contains 4 “action groups”:

1. Removing and binning all parts that should be replaced. This includes all O-rings.
2. Depending on the gas content the OCB inflator is exposed to, keep it in oxygen service.
The CGA (Compressed Gas Association), US Navy, UK’s HSE and the EIGA (European Industrial Gas Association) all recommend that breathing gasses with an oxygen content of 23.5% or higher should be treated as 100% oxygen. However, some technical training agencies still use 40% as the maximum percentage that is allowed for equipment that is not in oxygen service.
AP Diving advises to err on the side of safety, and to use the value of 23.5% as the cutoff percentage beyond which the equipment must be in oxygen service.
If in doubt: keep it in oxygen service, as that only takes a little bit more effort.
3. Ultrasonic-cleaning of all disassembled metal parts. This is mandatory if the OCB inflator is to be kept in oxygen service, but recommended in all other servicing situations.
4. Lightly grease new parts, fit them, and re-assemble the OCB inflator with the correct tools and the correct torques. Use oxygen-compatible grease, and avoid contaminating the metal parts after cleaning. Use the smallest amount of grease possible.

The use of rubber gloves while re-assembling the OCB is highly recommended to avoid rendering the OCB unclean due to human touch.

5.1 List of Parts to be Replaced during Service

As described in chapter 3.1, the following parts need to be replaced when servicing the OCB:

<u>NUMBER</u>	<u>DESCRIPTION</u>	<u>PART NUMBER</u>	<u>QUANTITY</u>
M8	O Ring on Location Screw	BS010 N70	1
M9	Non Return Valve Holder Seals	BS029 N70	2
M10	Mouthpiece Seal on Inner Tube	BS125 N70	1
M11	Inner O Rings on inside of Main Outer	BS48x2.5 N70	2
V1	Silicone Valve Seats	AP100_23	2
V2	O Ring on Counter Balance Piston	BS2.5x1 N70	1
V3	O Rings on Valve Seat Adjusters and Plunger	BS010 N70	3
V4	O Rings on Regulator Valve Body	BS14.5x2.5 N70	2

The following items are to be replaced as required, depending on inspection outcome:

M6 + M15	Non-return Valve Holder RH + One Way Valve	RB02_04 + RB02_05	1
M7 + M15	Non-return Valve Holder LH + One Way Valve	RB02_03 + RB02_05	1
F3	Diaphragm	RB112_5	1
M13	Cable tie for mouthpiece	AP21	1
M14	Mouthpiece	AP16	1

5.2 Ultrasonically Clean Deposits from all Metal Parts

Clean deposits from all metal parts, like chalk and salt.

! WARNING: Do NOT use aggressive chemicals. They might damage the metal coating. Use an ultrasonic cleaning bath with a suitable cleaning fluid instead. A good cleaning fluid is Biox "O2" immersion fluid. See WWW.BIOXINT.COM for further information and distributors.

5.3 Replace all O-rings with New Ones from the Service Kit

! WARNING:

- Replace all O-rings: do NOT re-use old ones.
- ONLY use original parts from APD, to ensure the O-rings:
 - o Are the exact size;
 - o Are of the correct material (especially important in a high oxygen content and overpressure environment);
 - o Are of the correct hardness (degrees Shore).
- Make sure you use only Oxygen-compatible grease.
- Also make sure you only use Oxygen-clean and Oxygen-compatible replacement parts.
 - o All APD-supplied O-rings in the service kit are made from Nitrile and as such are Oxygen compatible. However, they still need to be made Oxygen-clean.
- Last but not least: avoid touching Oxygen-clean parts after cleaning with your bare hands. Human body sweat and grease is not Oxygen-compatible. So use (e.g. surgical) rubber gloves when re-assembling the OCB.
- For photographic clarity no rubber gloves are worn on the photos below.

5.4 How to lightly grease O-rings

When greasing O-rings, make sure NOT to use too much grease.

Especially O2 compatible grease has the potential to become stiffer over time, which may cause a hardened clot of grease to become a source for leaking.

The best way to grease O-rings is using a simple "grease bag".

A grease bag is a clean and clear plastic bag, into which you put a small amount of grease. Optionally you can make two bags: one with O2 compatible grease, and one with normal silicone grease. Make sure you label them properly to avoid mixing them up! Also put a date on it, so you know how old your grease bag is. Don't use them longer than a year.

A nice advantage of using a grease bag is that you use only a tiny amount of grease for greasing many O-rings, so there is little waste.

We recommend that you use resealable bags, e.g. the ones with a plastic zipper, typically used for airtight food storage. This allows you to zip up the bag after use, keeping the contents clean for repeated use.

The simple steps are as follows:

- Take a plastic bag and deposit a SMALL amount of grease in it.



- Massage this grease all around the bag until it is evenly distributed over the inside surface area.
- Take the O-rings to be greased out of their storage container, either using gloves or using an O2-cleaned instrument like a dentist hook.



- Drop them in the grease bag, and from the outside of the bag move them around with your fingers, making sure they get in full contact with the grease.

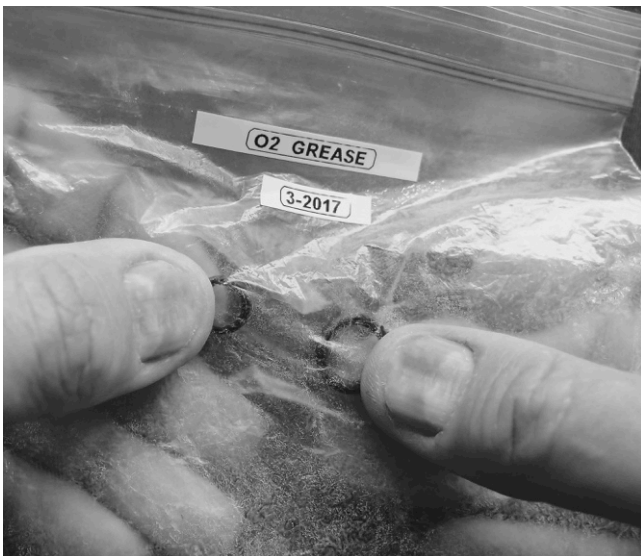

- Open the bag, and using a clean instrument like a dentist hook, take the now properly greased O-rings out.
- Inspect them to make absolutely sure that the grease is evenly and lightly distributed on the O-rings and that there are no areas of excess grease - no globs or strands.
- Fit them where they belong on your diving equipment, still making sure not to touch them with your bare hands.

6. Assembly Instructions

⚠ WARNING: When assembling the OCB, preferably use rubber gloves to avoid polluting it while assembling, rendering it not Oxygen-clean anymore. As this part may be exposed to high Oxygen content breathing gasses it is highly preferable it stays Oxygen-clean.

6.1 Optionally fit a new Original Mouthpiece onto the OCB Main Housing

- As indicated in paragraph 4.20, any damage found during inspection of the mouthpiece bite means a new mouthpiece bite must be fitted.
- APD **STRONGLY** recommends that you use their own mouthpiece bite (AP16), not a mouthpiece from other 3rd party manufacturers. There are two good reasons for this:
 - Using the correct mouthpiece bite ensures a perfect fit and grip on the collar of the OCB's main housing mouthpiece boss. If another mouthpiece does not have this exact fit and grip, there is a serious risk of the mouthpiece coming off during the dive, rendering the diver in grave and even potentially fatal danger. The AP original mouthpiece ensures the cable tie lies behind the raised lip on the OCB's moulded boss. Providing its cable tie is tightened sufficiently, it provides a strong, water tight and gas-tight connection.
 - The APD mouthpiece is designed in such a way that it guarantees the best work of breathing (WOB) and the least breathing resistance, aided by the larger size of its bite lugs. Some alternative 3rd party mouthpiece designs result in a much smaller gap between top and bottom teeth, leading to a higher WOB and a potentially increased risk of Hypercapnia.
- The original AP Diving mouthpieces have a recess on the inside that slips onto the raised rim on the boss of the main housing, as shown on the pictures below:

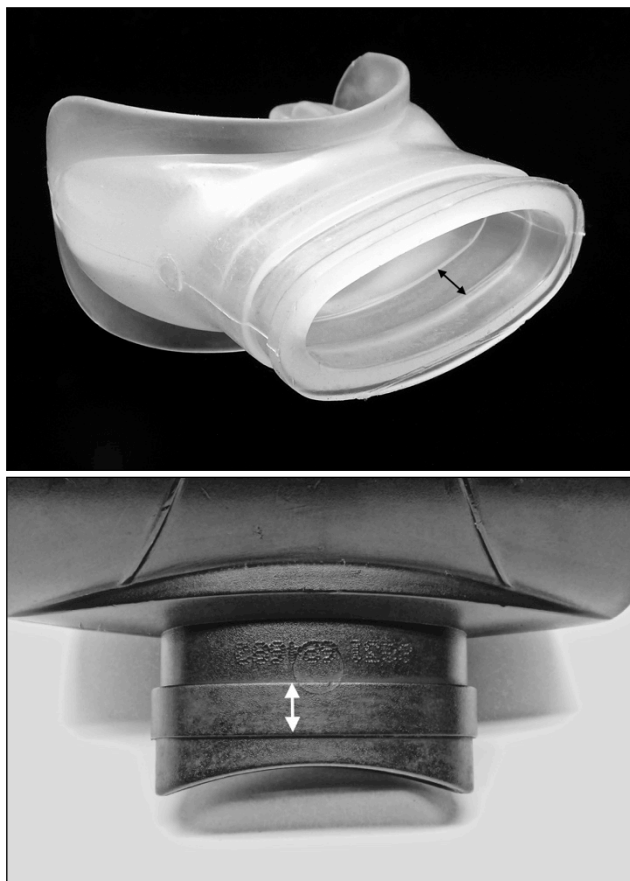

- When (re)fitting the mouthpiece, it is VITAL to make sure the groove on the mouthpiece falls properly and fully onto the rim on the OCB main body. Check this by rotating the mouthpiece on the boss of the main housing.
- The picture below shows correct positioning of the mouthpiece on the main housing. Note: there is no visible gap between the end of the mouthpiece and the main housing.



- The pictures below show INCORRECT positions of the mouthpiece on the main housing. Note: the visible gap between the end of the mouthpiece and the main housing. In the second example, the mouthpiece is also not properly aligned horizontally.
 - Both incorrect positions result in the recess inside the mouthpiece not hooking onto the raised rim on the boss of the main housing.



INCORRECT: visible gap



INCORRECT: no horizontal alignment

6.2 Fit new Cable Tie using Cable Tie Tension Gun

- APD **STRONGLY** recommends the use of the original cable ties they provide with their mouthpieces (AP21). Mouthpiece and cable tie are purchased together as a set using product code AP100D.
 - Paragraph 6.11.5 of the European EN14143:2013 NORM for rebreathers prescribes that a mouthpiece should be able to withstand a minimal pull of 80 Newton. With the AP Diving cable tie and correct tensioning using the correct tool it is possible to exceed a 200 Newton pull.
- APD **STRONGLY** recommends the use of a proper cable tie tension gun to tighten up the cable tie. Not using a proper tension gun and/or original cable tie could lead to a too low tension on the cable tie, potentially leading to the mouthpiece bite coming adrift from the OCB during the dive with potentially catastrophic results for the diver.
 - See paragraph 3.2 for a suggestion of proper cable tie tension guns that deliver sufficient tension.
- It is important that the grip block of the cable tie (its “lock”) is located to the SIDE of the mouthpiece, NOT on the top or bottom. Double-check these points before tensioning the cable tie.
- Tension the cable tie as much as possible, using a suitable cable tie tension gun.
 - Follow the setting instructions that come with the tension gun to make sure it applies a tension of at least 80 Newton.
 - For the Anvil tension gun used in the picture (see paragraph 3.2 for a link to its distributor) this means setting the gun to its highest position of 3.
- Test the mouthpiece bite by pulling it after fitting. If it appears as though it might come off, remove the cable tie and fit a new cable tie, ensuring it is tightened more.



6.3 Screw the Valve Seat Adjuster Back into the Valve Body



- Before assembly check the sealing surface of the valve seat adjuster with a magnifying eyeglass to check the surface for any imperfections or damage.
- Smear a new BS010 O-ring lightly with oxygen-compatible grease and place it onto the valve seat adjuster.
- Using a 5 mm Allen key, preferably one with a round top to avoid damage, carefully screw the valve seat adjuster into the valve body.
- Screw clockwise all the way in, and then 2 full turns back.

6.4 Re-Assemble Counter Balance Cylinder/Spring/Piston Assembly

NOTE: See also note in paragraph 4.12: the counter balance cylinder/spring/piston assembly as shown in the picture above and on other pictures is black in colour. However, APD changed the colour of the assembly from black to white in the beginning of 2009. So in the field you can find either black or white assemblies, depending on the age of the OCB. They are both manufactured from the same material.

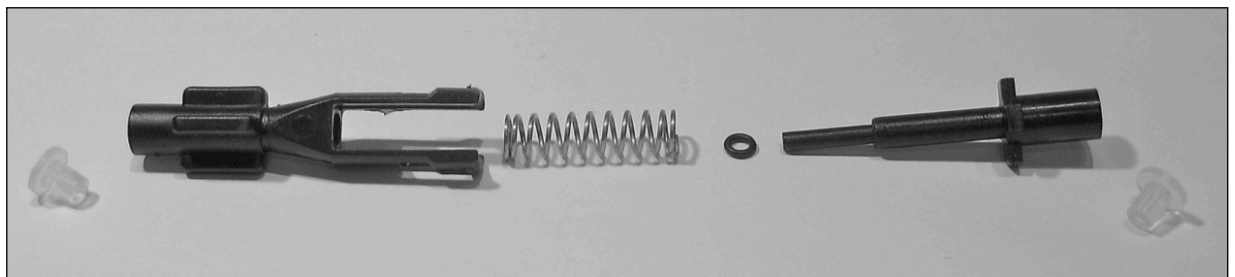
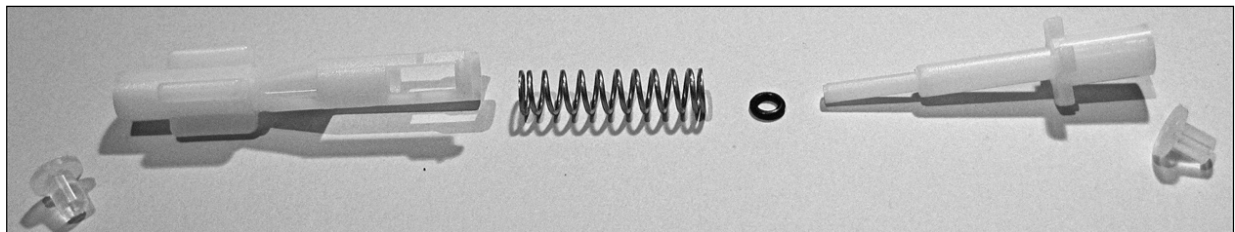

- Smear a very small amount of Oxygen-compatible grease onto the shaft of the counter balance piston.
- Fit a new O-ring (BS_2_6x1) on the shaft.

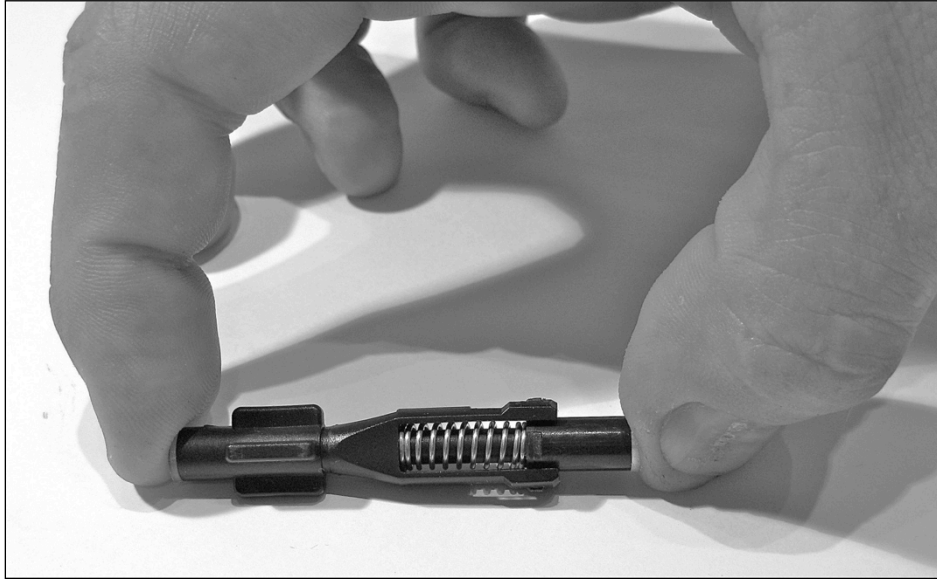

- Place the dual valve spring onto the counter balance piston.
- Assemble it into the counter balance cylinder, taking care when pushing the ends of the cylinder over the piston.
 - Take care to bend the ends out as little as possible to avoid deforming or breaking the legs of the cylinder part, rendering it damaged and unusable.
 - After assembly make sure the valve is running smoothly by compressing and releasing it with your fingers several times. It should not disengage.
- Fit new clear silicone valve seats on both ends.
 - Make sure there is no visible gap left between silicon seat end and the plastic housing.

6.5 Insert the Valve Body into the OCB Main Housing

- Insert the steel valve body into the main housing.
- Make sure the hole in the assembly is facing backwards, i.e. in the direction of the mouthpiece (the hole should not be visible when looking into it from the front).

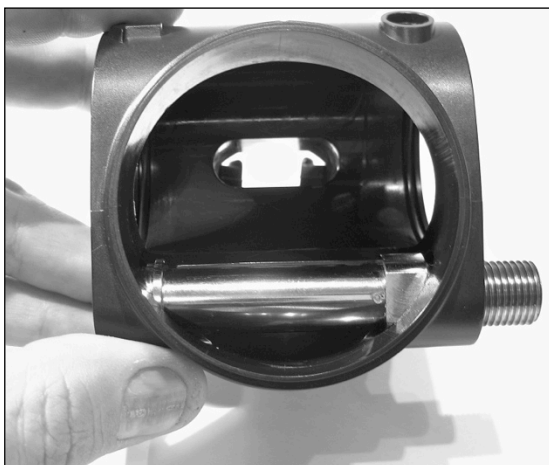

CORRECT: hole is NOT visible

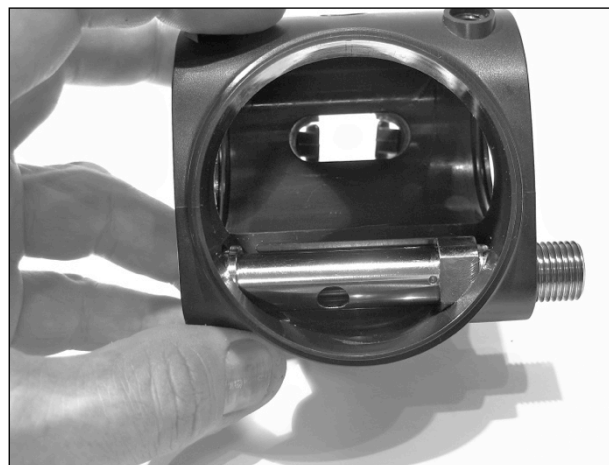

WRONG: hole is visible

6.6 Refit Lever

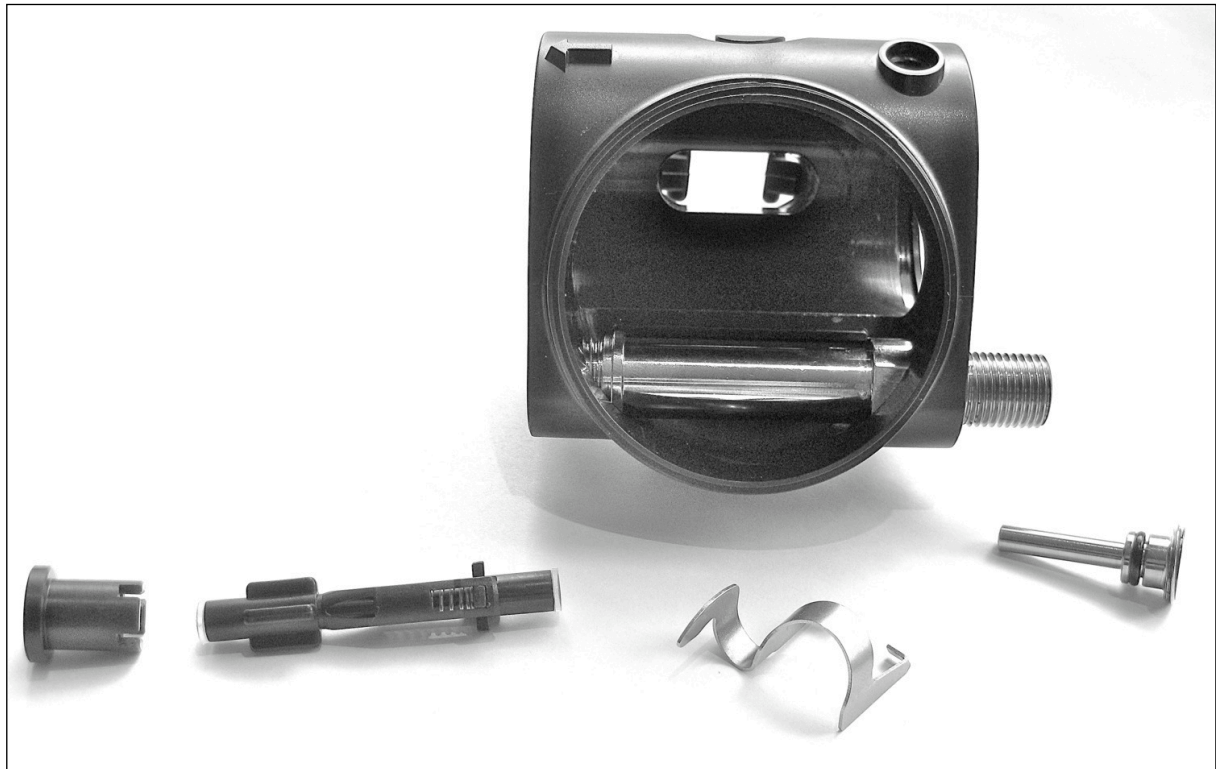

- Shown above are the position-fixing tool, the counter balance cylinder/spring/piston assembly, the lever and the steel piston.
 - The piston is used here again to facilitate compressing the counter balance cylinder, using a pinching motion as shown further below.

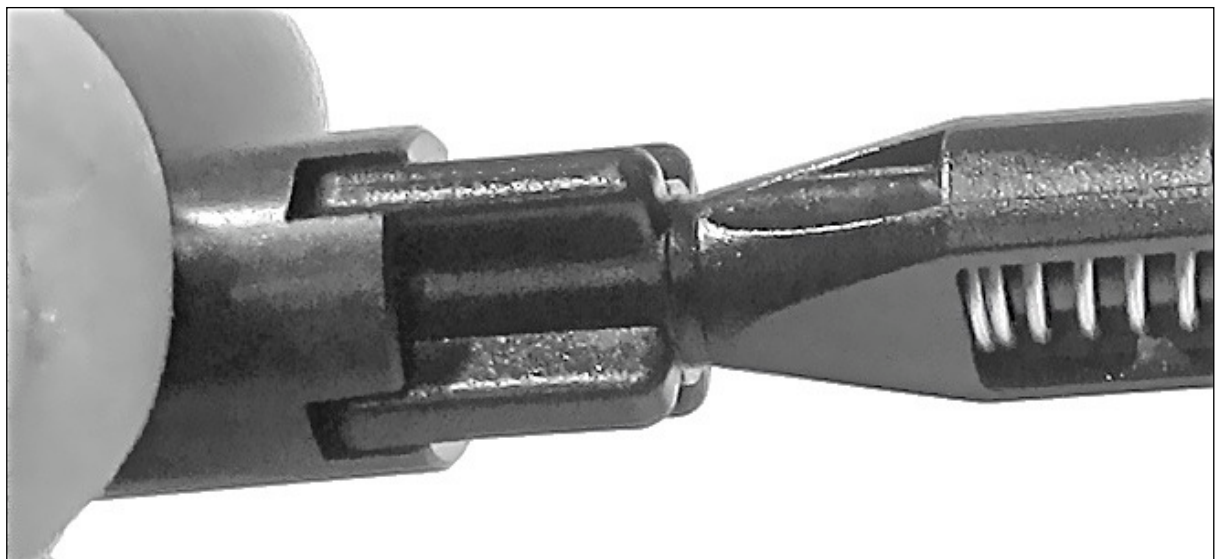

- Insert special position-fixing tool (RBTOOL13) onto the “wings” of the plastic counter balance cylinder, as shown above.

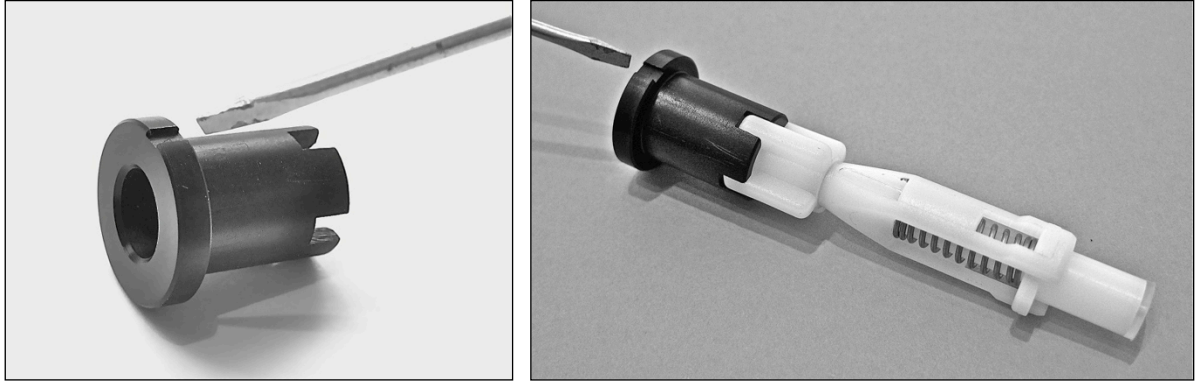

- RBTOOL13 has a small notch as indicated in the left side picture above.
- This notch should be aligned with the legs of the cylinder part of the counter balance cylinder/spring/piston assembly, as indicated in the right side picture above, i.e. the legs should be top and bottom, not left and right.
 - For clarity reasons, the white version of the assembly is used in the picture above. As indicated before, the black and white versions are alike.
- Make sure the notch in RBTOOL13 is always pointing up when inserting the assembly into the valve body.



- Using the position-fixing tool, insert the counter balance cylinder into the valve body; the spring-fitted piston end side goes in first.
 - Remember keeping the notch in the special tool, and thus the legs of the assembly, facing top and bottom.
- Next insert the steel plunger into the right side of the valve body.



- Compress the valve in one hand between thumb and fore-finger as shown above, applying pressure on both the special tool on the left side and the steel plunger on the other side of the valve body.



- By compressing, the holes are freed up to take the lever.
 - Make sure that the cylinder and piston components are properly orientated with the square opening in the valve body.
 - The above slot should be visible when pinching the plunger and special tool.

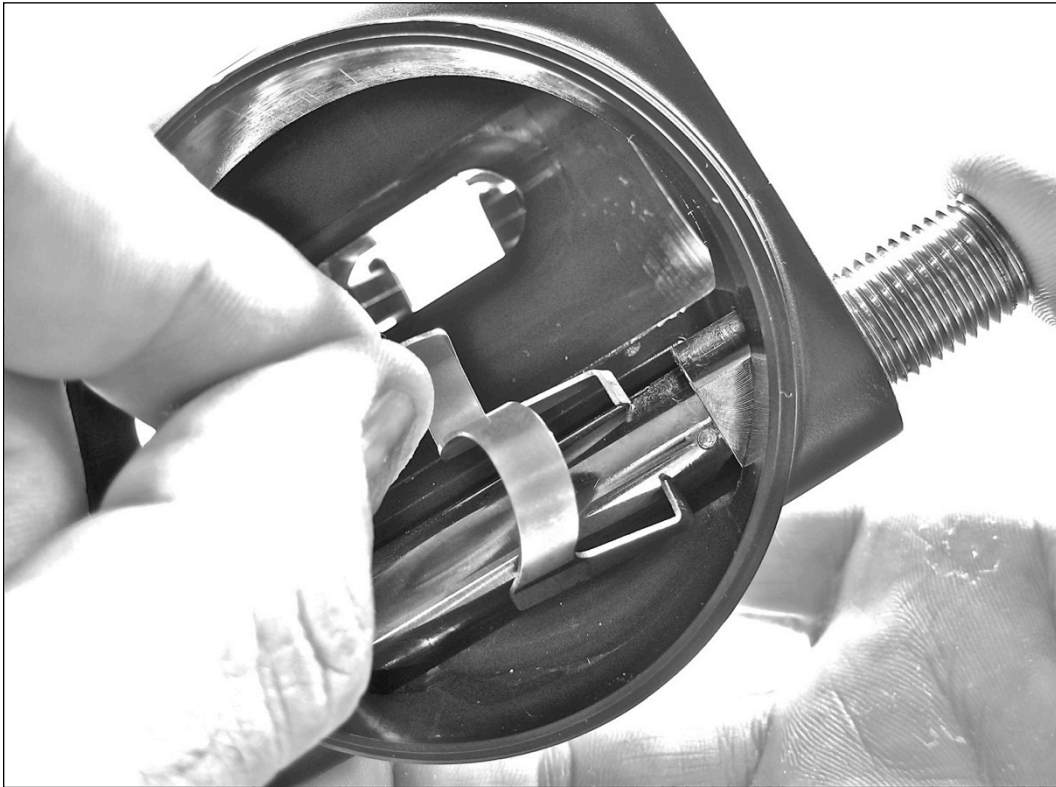

- Now REALLY GENTLY wiggle the lever and place it back into the two slots on top and bottom of the valve body, making sure you don't bend it out too much:
 - Twist it in on an angle, first fitting the upper "foot"
 - Do NOT use force, it should just "click" in place, falling into the holes.



- When you release the pressure by not pinching anymore, the lever should pop up.
 - Press the lever a few times gently to check for smooth movement.



- Next remove the plunger and special tool RBTOOL13, as shown above.

6.7 Push the Assembly through the Housing to the Right to Refit O-ring

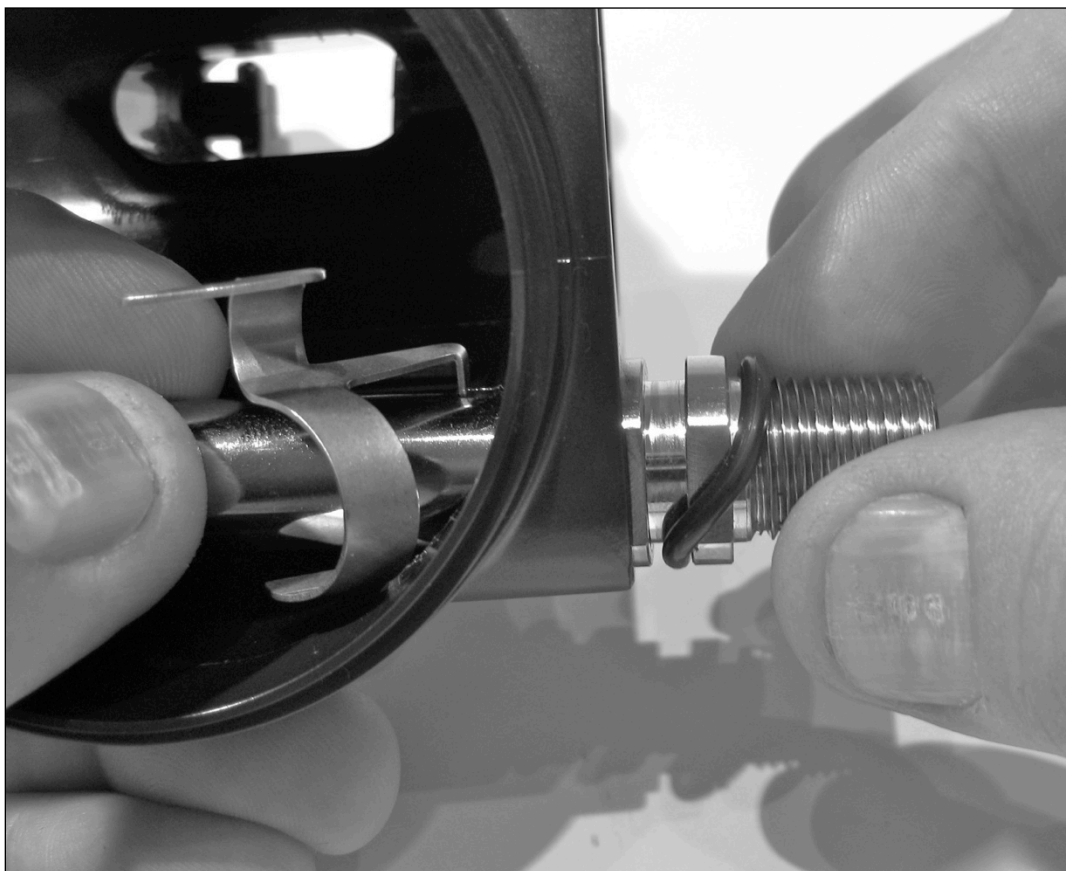

- Fit a new lightly greased O-ring into the groove.
- Push the assembly back in until it locks on the O-ring.

6.8 Refit Valve Seat Adjuster into the Valve Body End

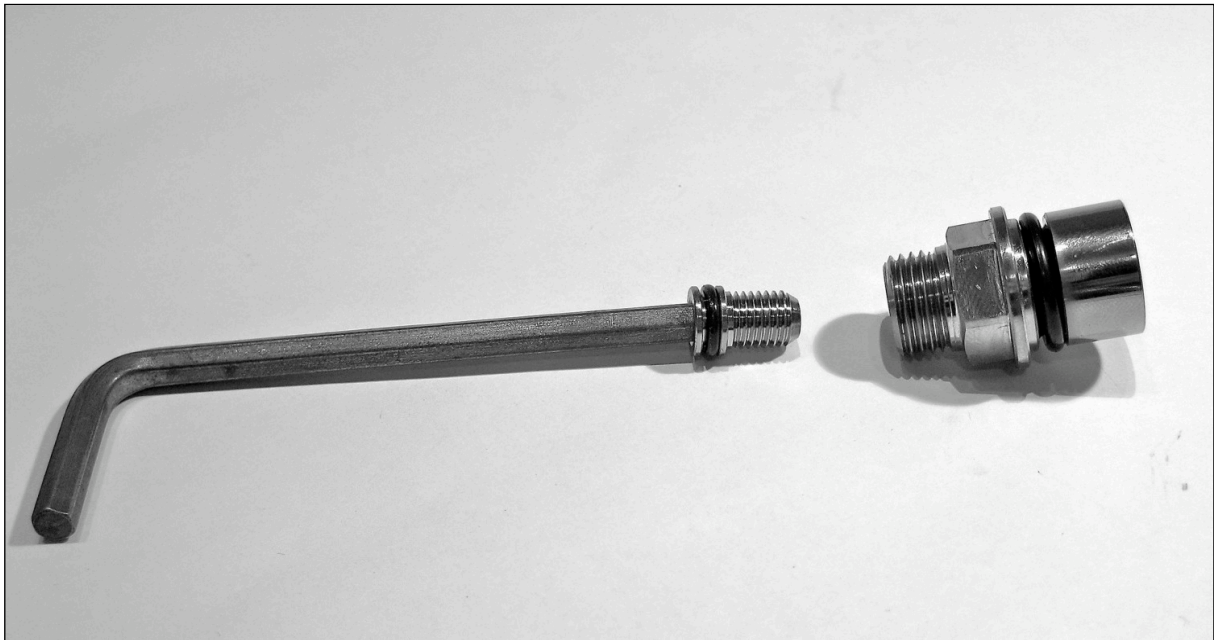

- Before assembly check the sealing surface of the valve seat adjuster with a magnifying eyeglass to check the surface for any imperfections or damage.
- Smear a new BS010 O-ring lightly with oxygen-compatible grease and place it onto the valve seat adjuster.
- Using a 5 mm Allen key, preferably one with a round top to avoid damage, carefully screw the valve seat adjuster into the valve body end.
 - Screw clockwise all the way in, and then 2 full turns back.

6.9 Refit 17 mm Nuts on Both Ends of the Valve Body

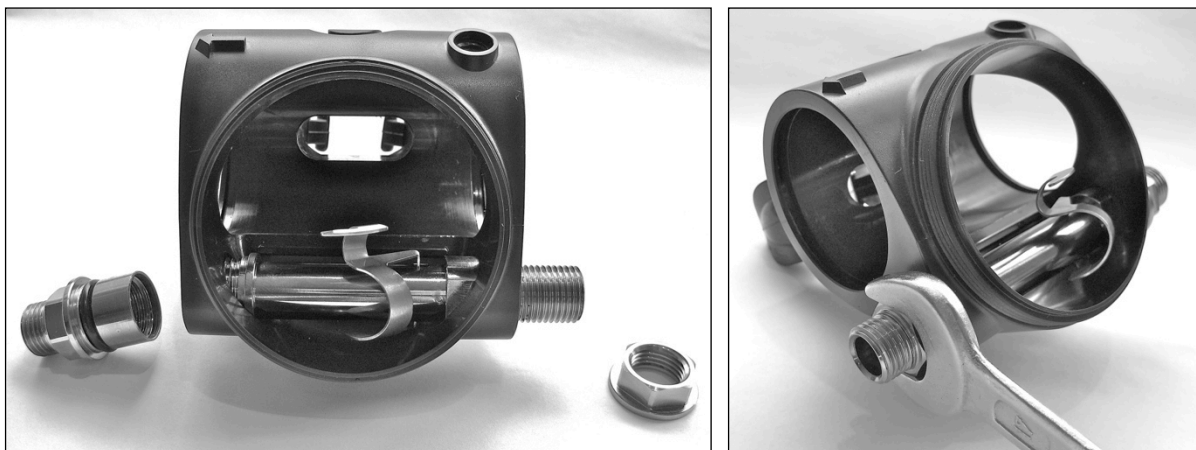

- Fit a new lightly greased O-ring onto the valve body end (see left picture).
- Use a 17 mm spanner to refit the left and right nuts.
 - Use a torque of 7 Nm
- The left nut will be slightly stiffer, as it has an O-ring inside that will cause some friction.

6.10 Refit the White Plastic Locking Lever

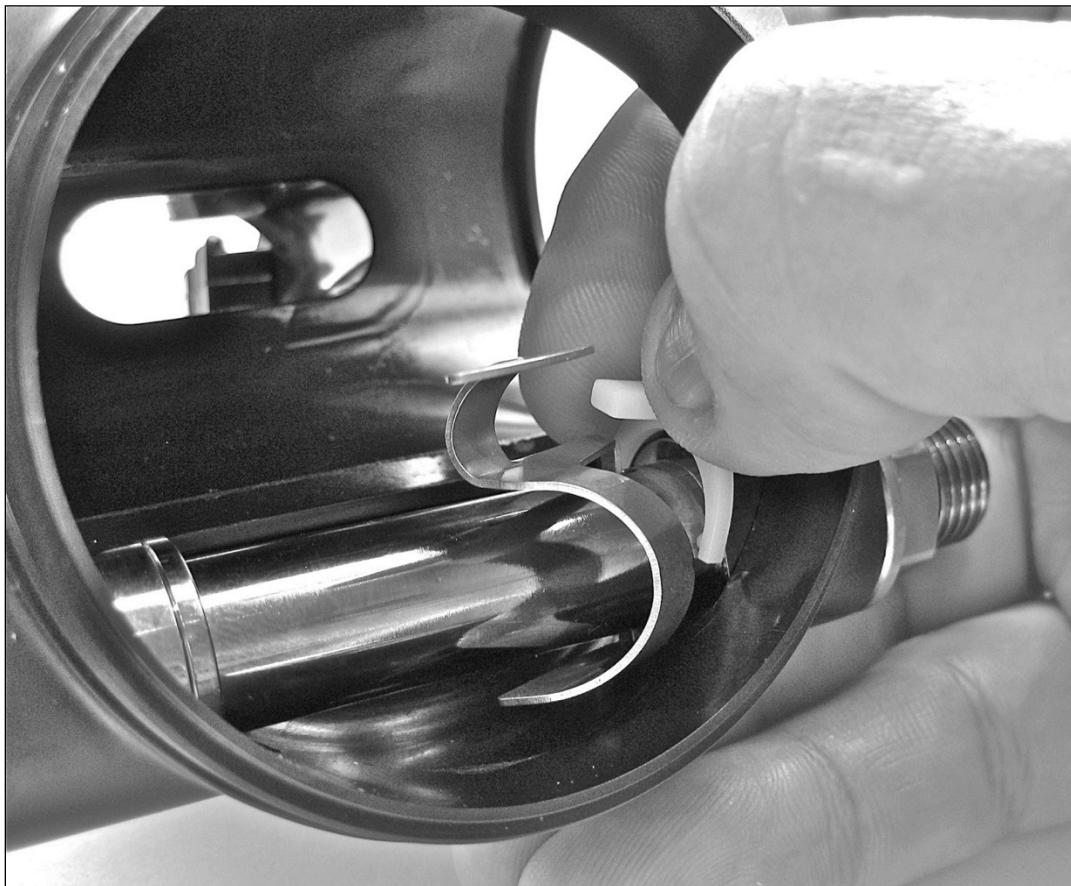
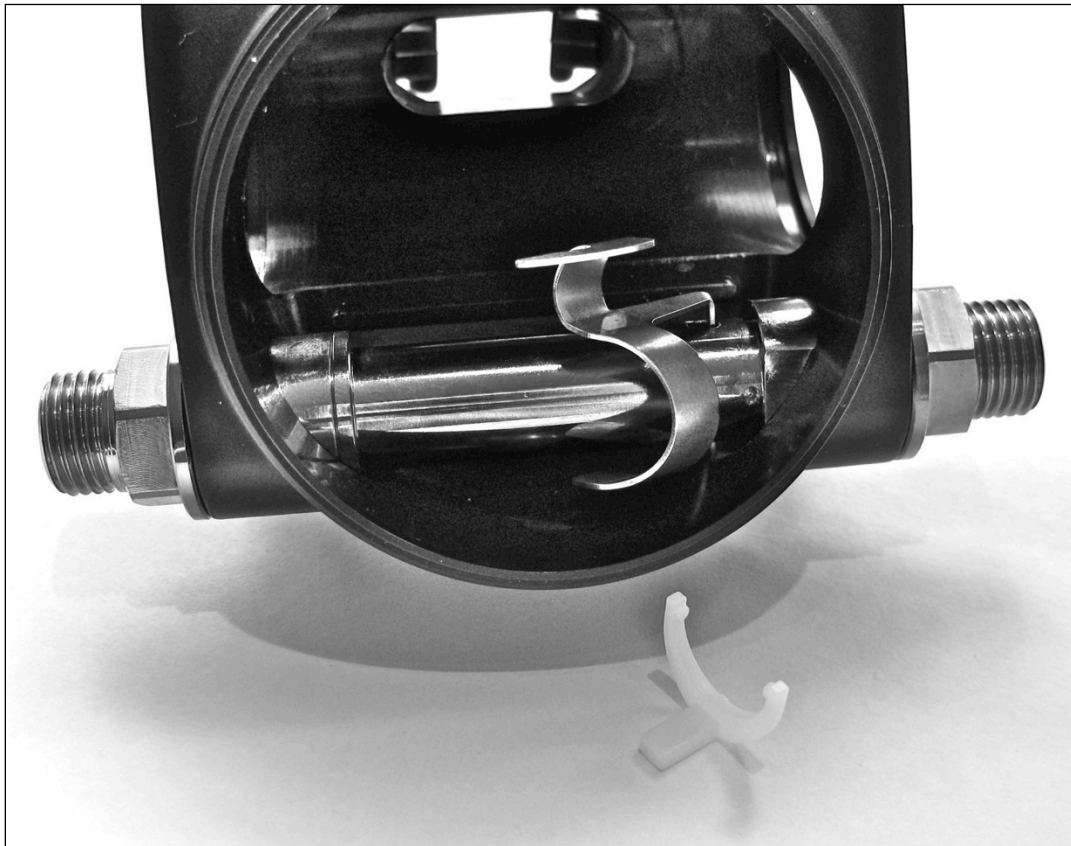

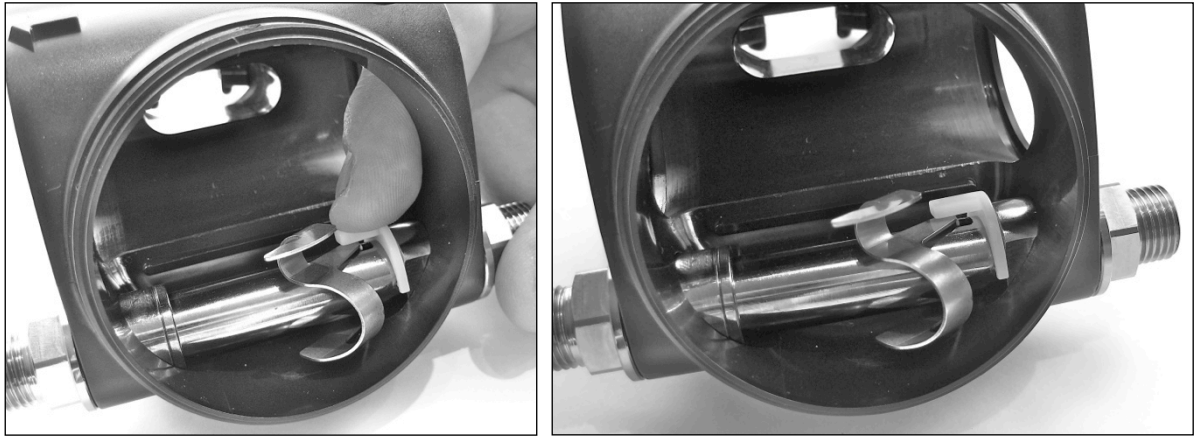

- Gently place the locking lever back into its position, using just your fingers.
 - Optionally gently push down the inserted leg of the lever a bit to make room.
- Make sure the location cams lock firmly into the small holes on both sides of the valve body.
- Make sure you do **NOT** damage the cams on the curved part of the locking lever. They have an important role in fixing the locking lever into its position.

6.11 Fit New O-rings Inside Both Ends of the Outer Housing

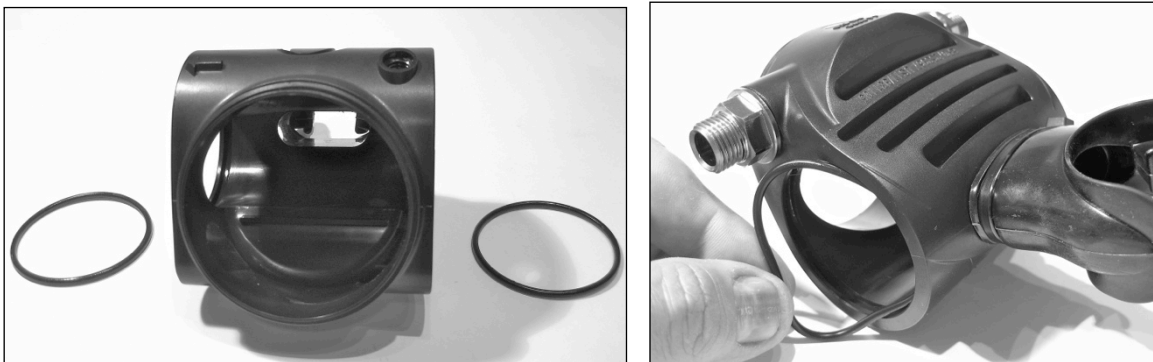

- Fit two new lightly greased O-rings in both ends of the outer body housing.

6.12 Replace the Non Return Valves into Both Ends of the Inner Tube





- Inspect the non-return valves and the diaphragms inside them for damage. If damaged, replace them.
- Fit new O-rings to the non return valve bodies after lightly greasing them
- The blue valve body has a groove that will fit over the small upstand inside the inhale side of the inner tube. Make sure you fit it on the correct side. NEVER use force.

6.13 Fit a New O-ring Around the Breathing Hole in the Inner Tube



- Fit a new dry (i.e. non-greased) O-ring in the groove around the breathing hole. Then lightly grease only the top of the O-ring.
 - If you put grease inside the O-ring groove before fitting it, it is possible that the O-ring can slide out of the groove when opening and closing the valve.

6.14 Insert the Internal Tube Back into the Outer Housing, from the Left

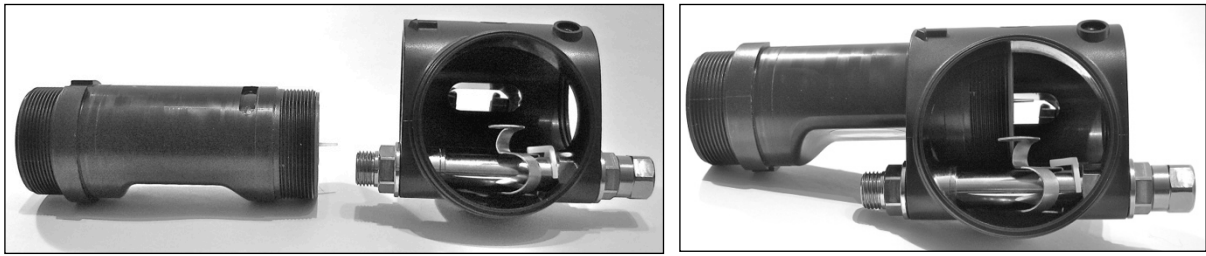

- Slightly grease the inner tube before fitting it back, especially the ends where they will touch the O-rings in the outer tube.
- Make a slight rotating movement while inserting it into the outer housing, making sure the breathing hole on the inner tube points in the direction of the mouthpiece.
 - Make sure you do not jam either the O-ring around the breathing hole or the ones in the outer tube. Do NOT use force!

6.15 Replace Locking Screw into the Outer Housing

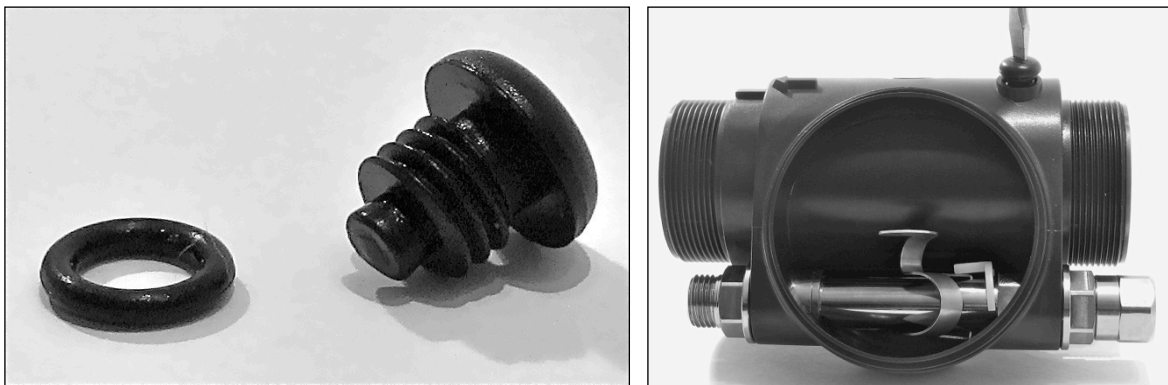

- Fit a new lightly greased O-ring on the locking screw.
- Use a 3.5 mm screwdriver.
 - Take care to NOT over tighten.

6.16 Refit Yellow Lever on Left Side of Tube

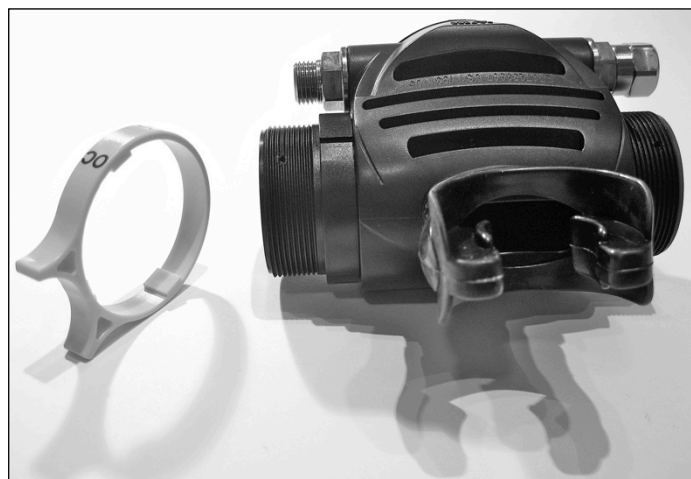



- Refit the yellow lever, fitting the cams on the lever onto the corresponding holes on the inner tube.
- Make sure the “OC” inscription sits above the “CC” inscription when looking from the front, as indicated in the picture above.
- Check for smooth rotating action after fitting.

6.17 Refit Front Cover Assembly



- Inspect the diaphragm with its integrated exhaust valve for any damage, then fit the diaphragm, making sure the groove in the diaphragm fits fully on the rim of the outer housing.
- Next fit the skid disk, with the flat side down (i.e. flat side facing the diaphragm).



- Next fit the yellow rubber cover with the APD logo.
- Finally fit the locking ring while keeping the rubber cover so that the AP Diving text sits nicely horizontal, as shown on right picture above.

6.18 Refit Corrugated Hoses and Hose Collar Screws



- Just to be sure, once more inspect the non-return valves and their internal diaphragms for damage or dirt before fitting the corrugated hoses.
- Next screw the corrugated hoses back on, noting the position of the holes for the two small S/S hose collar screws.
 - Use “blue on blue”, i.e. fit the corrugated inhale hose with the blue rubber marker rings onto the left side of the OCB, which is the side fitted with the blue non-return valve.
- Use the markings you made previously during disassembly (paragraph 4.2) when you removed the screws to find the same position again for taking the S/S hose collar screws.
- Inspect the sealing O-rings inside the hose collars. If damaged or flat, replace them
- Screw the S/S screws back into the collars again.
 - Be gentle; do NOT use force: it is quite easy to overtighten the screws and thus damage the thread in the collars. Remember that the only function of these screws is to prevent rotation of the collars on the thread in the inner tube.

6.19 Refit Blank End Cap and Plunger

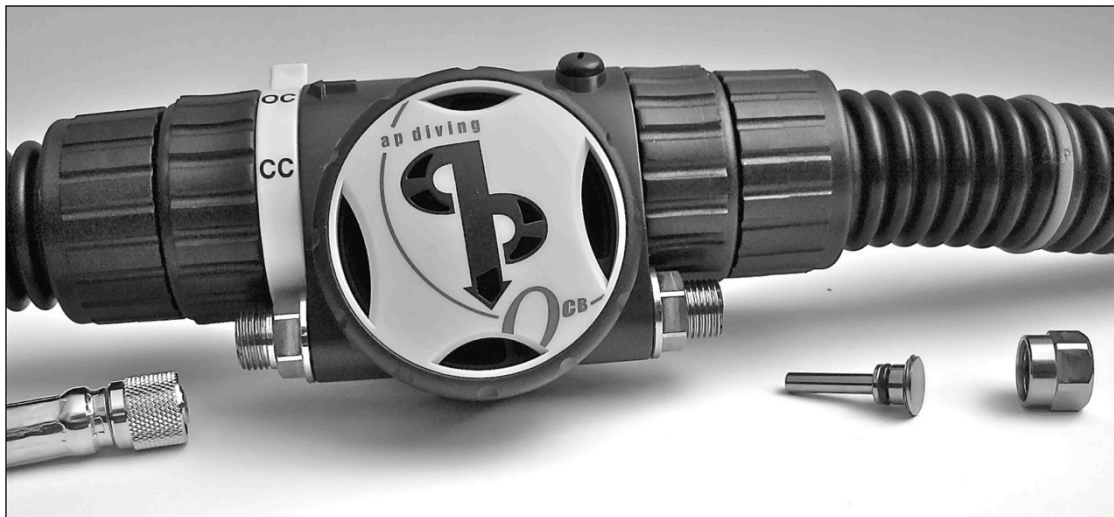

- Fit a new O-ring onto the plunger.
- Next screw the plunger all the way through the thread in the blank end cap so that it disengages from the thread.
 - You can check this by pulling on the plunger: if it has fully disengaged from the thread in the end cap, you can move the plunger a bit in all directions.



- Next screw the blank end cap with the plunger inside, onto the opposite end to where you will be attaching the MP hose.
 - Fitting it hand-tight should be enough, but just nip it up with a 17 mm spanner to avoid accidental loosening.

6.20 Refit MP Hose



- Replace the O-ring with a lightly greased new one.
- Screw the hose back on, finger-tight.

6.21 Update 11-2018: Refit the updated Yellow Lever on Left Side of Tube

As already mentioned in paragraph 1.4, in November 2018, AP Diving introduced an updated version of the yellow lever.

This updated version facilitates a much easier one-handed operation of the OCB.

This has been realised by repositioning the two protruding triangular lever tabs on the lever to a new position whereby the OCB can be switched from the open to the closed position v.v. with a pinching movement between the associated lever tab and the blank endcap.

The updated lever is fully backwards compatible with all existing OCB's, i.e. it can be retroactively fitted to any OCB already out in the field, by simply swapping out the old version for the updated one.

The updated lever is shown in the pictures below. You can clearly see that the new lever has broader grips than the previous version, and in different positions.



Previous (pre 11-2018) lever



New (post 11-2018) lever



New (post 11-2018) lever

Fitting this new lever can be done in the very same way as fitting the previous version, as described in paragraph 6.16 above:

- Refit the yellow lever, fitting the cams on the lever onto the corresponding holes on the inner tube.
- Make sure the “OC” inscription sits above the “CC” inscription when looking from the front, as indicated in the picture below.
- Make sure the lever tabs are on the bottom of the OCB, not on the top.
- Make sure the protruding parts of the lever tabs are on the outside, away from the centre part of the OCB (as shown). If they are on the inside, the lever ring is fitted the wrong way around and will not function correctly.

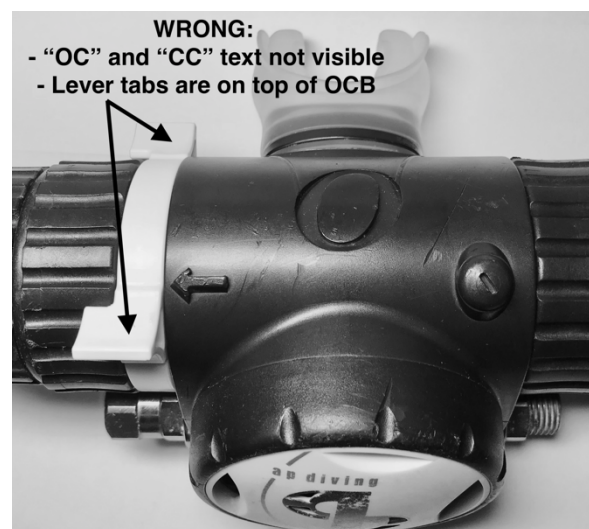
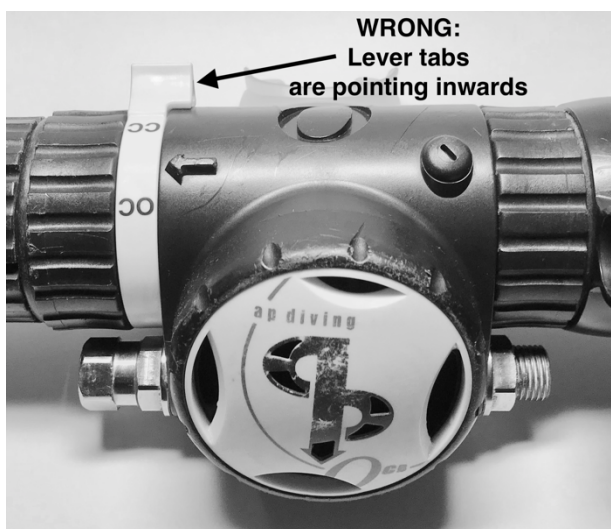
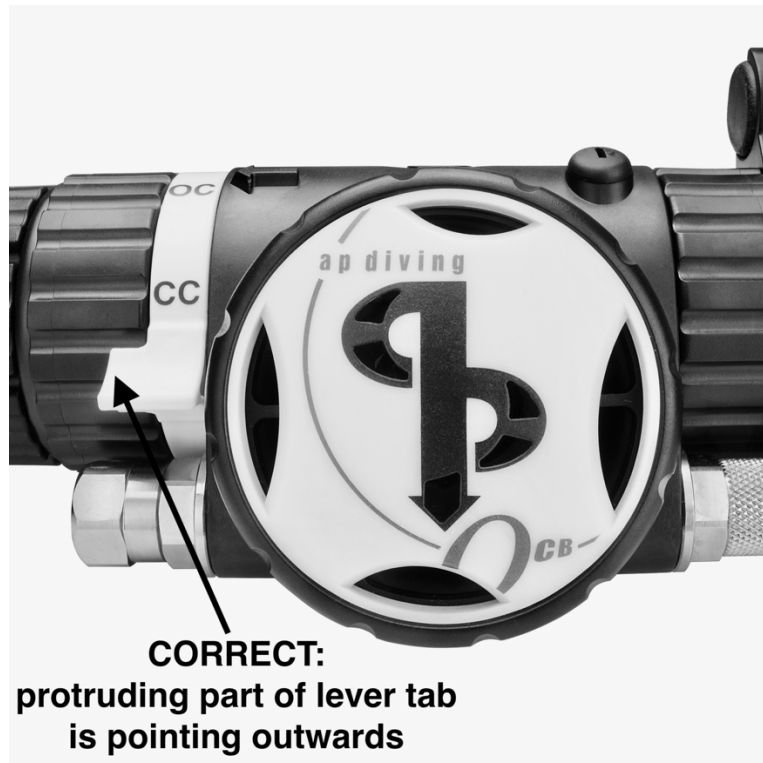

- Check for smooth rotating action of the lever after fitting.

7. Testing Instructions

7.1 Check Airtight Sealing in OC Mode

- Switch the OCB to OC mode, using the yellow lever.
Either:
 - Attach the MP hose and close up the 1st stage end of the hose by either attaching it to a 1st stage, or (when not connected to a 1st stage) simply block the end of the hose by sealing off with your finger;
 - If attached to a 1st stage, make sure that stage is connected to a closed cylinder, as otherwise it is still possible to suck air through the 1st stage when it is unconnected.
- Or:**
 - Detach the MP hose, and block off the now exposed valve body end with your finger.
- Put the mouthpiece in your mouth and try to suck air in: this should not be possible.
- Test the exhaust valve by blowing out through the mouthpiece: this should go without noticeable effort or delays.
- Repeat the above inhale and exhale actions a few times to make sure no leaks exist in the OC parts.
- If leaks are found (i.e. it is possible to continue to suck in air), inspect:
 - the diaphragm;
 - the exhaust valve;
 - the O-ring on the inner tube around the mouthpiece;
 - the O-ring on the small location screw on top of the main house.

7.2 Check Airtight Sealing in CC Mode

- Switch the OCB to CC mode, using the yellow lever.
- Hold the inhale corrugated hose (with the blue rings) against your cheek, and try to suck air in through the mouthpiece.
- The corrugated hose should now build up a bit of vacuum, and should “stick” to your cheek when you take the mouthpiece out of your mouth.
 - This is due to the non-return valve functioning well.
- Any further attempts to suck in more air should not work.
 - If the hose does stick to your cheek, but it is nevertheless possible to continue to suck in air, inspect:
 - the mouthpiece and its cable tie for damage;
 - the O-ring on the inner tube around the mouthpiece;
 - the O-rings in the collars of the corrugated hoses;
 - the O-ring on the small location screw on top of the main house.
- Try to blow into the end exhale corrugated hose. This should not be possible.
- Hold the exhale corrugated hose against your cheek and try to blow through the mouthpiece. This should not be possible.

7.3 Check for Smooth Movement between OC and CC Mode

- Move the yellow lever a few times to verify proper and smooth switching operation between the OC and CC modes.
 - Combine this with the airtight tests of paragraphs 7.1 and 7.2 above.

7.4 Remove Front Cover Assembly

- See paragraph 4.4 for detailed instructions.

7.5 Adjust Right-hand Valve Adjuster, Checking Correct Lever Height with RBTOOL15

- Attach the MP hose to an oxygen-clean MP air supply, and then to the right side of the OCB.
- Turn the air supply on and depress the lever a few times.

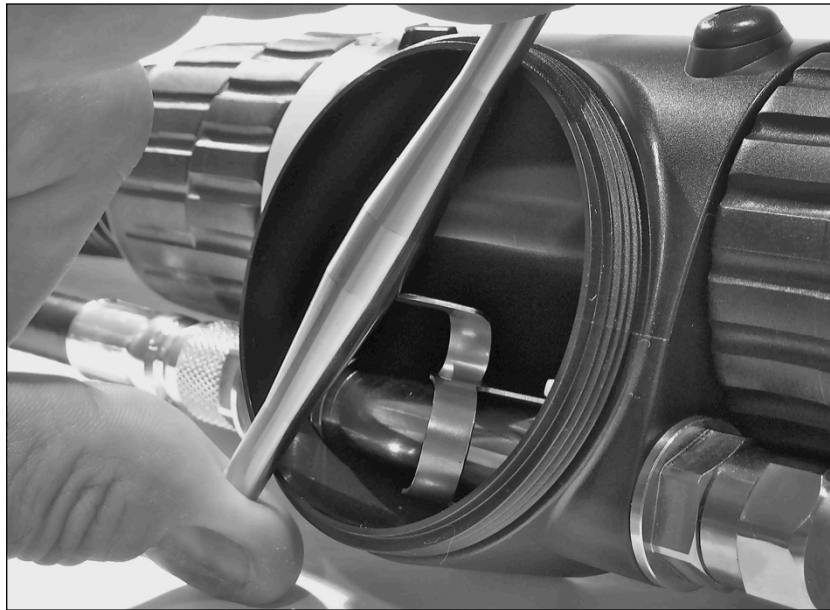

- Using the adjuster tool RBTOOL15 as shown, simply roll it over the lever to check the correct height. The thin outside of RBTOOL15 should rest on the rim of the housing, while the thicker center part is used to check the lever height.



- The thicker center part of RBTOOL15 should just touch the lever.

- Check for proper position of the lever by gently pushing it down a few times by hand, followed by re-checking the correct height with RBTOOL15.
- If it is not correct turn off the air supply, release the pressure by depressing the lever and remove the MP hose.

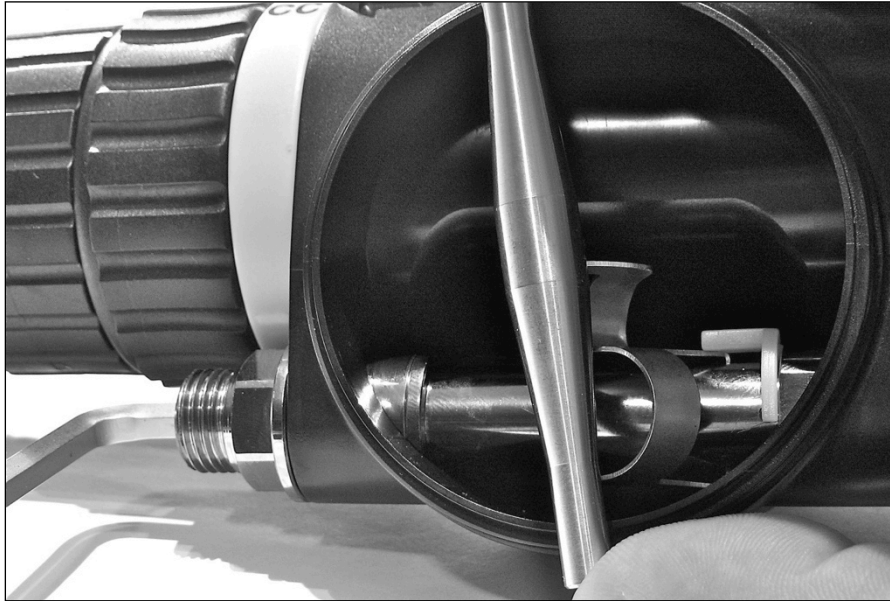

- Using a 5 mm Allen key (preferably one with a round top) insert it into the now exposed valve seat adjuster.
 - Rotate the Allen key anti-clockwise to raise the lever and clockwise to lower it.
 - You can optionally use RBTOOL15 as a reference to check the amount of change in height. Typically use only 1/8 turns at a time.
- Re-attach the MP hose, turn the air back on and re-check the height of the lever.
- Repeat the steps above until the lever height is correct.

7.6 Adjust Left-hand Valve Adjuster, Checking Correct Lever Height with RBTOOL15

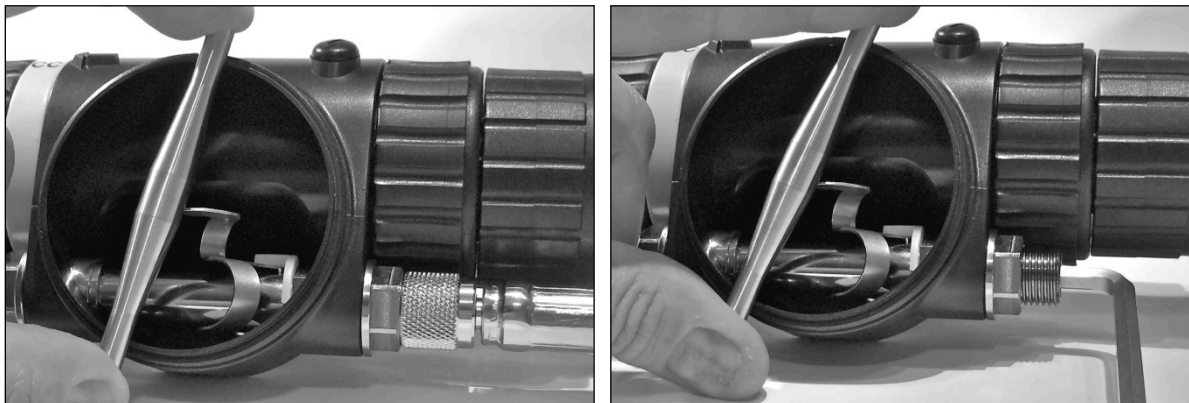

- After adjusting the right hand side of the OCB, swap the blank end cap with its plunger inside over from the left side of the valve body to the right side.
 - See paragraph 6.17 for detailed instructions.
 - Make sure you screw the plunger all the way into the end cap so that it disengages again from the thread before fitting it.
- Repeat the height adjustment setting steps as described above in paragraph 7.5

7.7 Refit Front Cover Assembly

- See paragraph 6.15 for detailed instructions.

7.8 Test for Leaks and Breathing Quality by Attaching the OCB with its MP Hose onto a 50 bar Oxygen-Compatible Clean Air Source

- After adjusting both valve adjusters and refitting the front cover assembly, repeat the checks for airtight sealing and smooth lever operation as described in paragraphs 7.1, 7.2 and 7.3 above.
- Especially check for free-flow by pressing the purge button:
 - While in CC position there should be no free-flow.
 - In the OC position if the purge button is pressed while the mouthpiece is out of your mouth, the valve will free-flow due to the venturi effect.
Simply seal off the mouthpiece to stop the free-flow.
- Re-attach the MP hose as described in paragraph 6.18 to the left hand side of the OCB, and connect it to an oxygen-clean medium pressure air source.
- The ideal medium pressure for the OCB is 9.5 bar. However, the OCB is a balanced design and will function within a medium pressure range of between 8 to 13 bar. We recommend however testing and adjusting, and in fact also using the OCB with an intermediate pressure of 9.5 bar.
- Slowly open the tank valve while keeping the purge button (yellow front cover) of the second stage pressed.
- Now release the purge button from the OCB and listen for any leaks.
- Next submerge the OCB in water to check for any leaks.
- Breathe in very slowly and softly, but also breathe in hard and fast a few times. The breathing should be smooth, without noticeable resistance or delays.
- As a final precaution, inhale when the air is turned off to ensure no air can be drawn in. This tests for an ill-fitting diaphragm or any other leak.

7.9 Check Proper Breathing also in Right Hand Mode

- Swap over the MP hose from the left to the right hand side of the OCB.
- Swap over the blank end cap with its plunger inside from the right to the left hand side of the OCB.
 - See paragraphs 6.17 and 6.18 for detailed instructions.
- Repeat the test steps as described in paragraph 7.8 above.



NOTE: The newly fitted silicone valve seats (see paragraph 6.4) should ideally be given some time to “sink in” against the sharp edges of the valve seats, under the pressure of the internal spring.

This does not just apply to the OCB, but to ANY regulator that has new valve seats fitted. The “sinking in” may cause a tiny fraction of extra room that may just be enough to cause free-flowing or a small leak after a day or so, if the tuning of the OCB is done directly after replacing the seats as part of the service.

So if at all possible, perform the servicing of the OCB on day one, then let it rest overnight, and do the tuning and adjustment on the next day.